



August 19th, 2024
Mr. Leo Cosentini
California State Water Resources Control Board
Division of Water Quality
P.O. Box 100
Sacramento, CA 95812-0100

Dear Mr. Cosentini,

Thank you for this opportunity for Fabco Industries, Inc. to submit a revised application to the California State Water Resources Control Board for certification of the **Fabco CPS (Application 36)** as a Full Capture System -Trash Treatment Control Device. The revised application is in accordance with the April 2024 update of the Application Requirements for Trash Full Capture System Certification. New optional components for the U and L-Shape configurations of the CPS have been added to the revised application. While the top cover for the Fabco CPS is mandatory in all installations, a perforated version of the mandatory top cover is a new option included in the application. The perforated option for the mandatory top cover utilizes the same stainless-steel sheet metal with \emptyset 3/16" round openings as the filter screens of the Fabco CPS. Vector control access remains unchanged with the perforated top cover. The other new option added is a quick release mounting for the Fabco CPS. The quick release mounting is comprised of mounting plates which are directly installed to the catch basin walls, allowing the Fabco CPS screen assembly and top cover to be mounted and removed for maintenance from the mounting plates with no need for tools.

As a brief description of the device, the Fabco CPS is a connector pipe screen device which mounts to the basin walls around an outlet pipe. The device screens all particles 5 mm in diameter or greater; and allows for a filtered flow rate through the device equal to or greater than the peak flow of the storm drain in which it is installed. Provisions have also been made to ensure that standing water does not build up and Mosquito Vector Control personnel are easily able to inspect the device without needing to lift grates or perform confined space entry. The Fabco CPS has been installed and successfully protects waterways in stormwater infrastructure projects nationwide, including in California within the cities of Garden Grove, Antioch, and Escondido.

Within our application below we have spoken to each of the submittal requirements within the Trash Treatment Control Device Certification and Fact Sheet Update Requirements and maintained the requested layout.

Thank you again for your consideration and time taken to review our application. If any additional information is needed please do not hesitate to contact myself Hilme Athar or our V.P. of Engineering, John Peters. Both of our contact information can be found within the application below.

Sincere regards,

A handwritten signature in black ink that reads "Hilme Athar".

Hilme Athar
Sales Engineer
24 Central Drive
Farmingdale, NY 11735
(631) 393-6024
hathar@fabco-industries.com

1. Cover Letter

1.A. Device Name and General Description

The Fabco Connector Pipe Screen (CPS) (**Application 36**) is a full capture trash screening device designed and manufactured by Fabco Industries. The device is designed to install directly around the outlet pipe opening of a catch basin. There are three configurations available of the Fabco CPS: the V-Shape, U-Shape, L-Shape. The device's stainless-steel screens with $\varnothing 3/16''$ (~ 4.8 mm) round openings filter any trash larger than 5 mm in diameter from stormwater drainage. The filtered trash then remains trapped within the catch basin for removal. The CPS is fabricated completely from stainless-steel and steel concrete anchors used for mounting the device.

1.B. Applicant's Contact Information and Location

Owner Information:

John Peters
V.P. of Engineering
390 Oser Avenue
Hauppauge, NY 11788
(631) 393-6024
johnp@fabco-industries.com

Authorized Representative(s) Contact Information:

Justin Cohen
Senior Project Engineer
390 Oser Avenue
Hauppauge, NY 11788
(631) 393-6024
jcohen@fabco-industries.com

Hilme Athar
Sales Engineer
390 Oser Avenue
Hauppauge, NY 11788
(631) 393-6024
hathar@fabco-industries.com

1.C. Manufacturer's Website Page for Device

<https://fabco-industries.com/trash-capture-filter-device-connector-pipe-screen/>

1.D. Device's Manufacturing Location

Fabco Industries, Inc.
390 Oser Avenue
Hauppauge, NY 11788
(631) 393-6024

1.E. Brief Summary of Field/Lab Testing Results

The Fabco CPS captures trash from stormwater drainage using stainless-steel screens with $\varnothing 3/16''$ (approximately $\varnothing 4.8\text{mm}$) round openings. When installed within a catch basin or stormwater vault, the entire surface runoff design flow is directed through the screens so all trash 5 mm or greater in diameter is physically captured from the peak design flow and retained within the catch basin. No lab testing is required as all trash 5 mm and greater in diameter are physically blocked by the screening material from flowing past. Existing installations of the CPS, including project sites in California, have yielded only positive results. All filtered flow rates reported in the hydraulic capacity tables (Section 3.C.) have been calculated using the percent open area of the screens, pressure head measured to the bypass of the device, and a standard coefficient of discharge of 0.62 for the orifice equation.

1.F. Brief Summary of Device Limitations, and Operational, Sizing, and Maintenance Considerations

The Fabco CPS is available in standard sizes to fit and operate for standard pipe diameters utilized in stormwater management. Custom sizing to meet site-specific design flow and dimensional criteria can also be requested. A masonry drill, measuring tool, and 9/16" socket wrench (or equivalents) are the only tools required for installation of the CPS. Mounting points on the device are designed to be as accessible as possible with the required tools. The restricted space of a catch basin is greatly considered in the design and engineering. A mandatory vector control access door is ensured on all CPS devices installed in California to allow access behind the CPS screens by Mosquito Vector Control Personnel without need for confined space entry.

The filtered flowrate of the Fabco CPS is designed to completely screen at least the trash treatment peak design flow of a storm drain. Regular maintenance is necessary for the CPS to function properly. Fabco typically suggests maintenance be scheduled twice a year, but true necessary maintenance frequency will depend on site-specific conditions. The applicable Municipal Stormwater permit may specify more frequent maintenance intervals as well. Fabco Industries recommends the use of a vacuum truck to most easily clean captured trash. CPS units are sized to maintain hydraulic capacity prior to required maintenance as specified by an applicable Municipal Stormwater permit.

1.G. Description, or List of Locations, where Device has been Installed.

Fabco CPS units have been installed for stormwater management projects throughout California and nationally. Below are some example current install sites within the state of California:

Current Install Sites	
Project	Contact
Garden Grove, CA	Patrick Murphy Area Sales Manager
Antioch, CA	Ferguson Waterworks, Geo & Stormwater Solutions
Escondido, CA	Phone: 916-402-3210 Email: Patrick.Murphy@ferguson.com

1.H. Certification

I certify under penalty of law that this document and all attachments were prepared under my direction or supervision in accordance with a system designed to assure that qualified personnel properly gather and evaluate the information submitted. Based on my inquiry of the person or persons that manage the system or those persons directly responsible for gathering the information, to the best of my knowledge and belief, the information submitted is true, accurate, and complete. I am aware that there are significant penalties for submitting false information, including the possibility of fine and imprisonment for knowing violations.

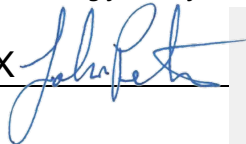
X 

John Peters
V.P. of Engineering
(631) 393-6024
johnp@fabco-industries.com

2. Table of Contents

1. Cover Letter	1
1.A. Device Name and General Description	1
1.B. Applicant’s Contact Information and Location	1
1.C. Manufacturer’s Website Page for Device	1
1.D. Device’s Manufacturing Location	1
1.E. Brief Summary of Field/Lab Testing Results	1
1.F. Brief Summary of Device Limitations, and Operational, Sizing, and Maintenance Considerations	2
1.G. Description, or List of Locations, where Device has been installed	2
1.H. Certification	2
2. Table of Contents	3
3. Physical Description	4
3.A. Trash Capture	4
3.B. Peak Flows/Trash Volumes	4
3.C. Hydraulic Capacity	5
3.D. Comparison Table	8
3.E. Design Drawings	8
3.F. Optional Components	9
3.G. Bypass	10
3.H. Feeder Troughs	10
3.I. Calibration Feature	10
3.J. Previously Trapped Trash	10
3.K. Material Type	11
3.L. Design Life	12
4. Installation Guidance	13
4.A. Standard Device Installation Procedures and Considerations.....	13
4.B. Description of Device Installation Limitations and Non-Standard Device Installation Procedure	13
4.C. Methods for Diagnosing and Correcting Installation Errors	14
5. Operation and Maintenance Information	15
5.A. Inspection Procedures and Frequency Considerations	15
5.B. Description of Maintenance Frequency Considerations	15
5.C. Maintenance Procedures	15
5.D. Essential Equipment and Materials for Proper Maintenance Activities	16
5.E. Description of the Effects of Deferred Maintenance on Device Structural Integrity, Performance, Odors, etc.	16
5.F. Repair Procedures for Device’s Structural and Screening Components	16
6. Vector Control Accessibility	17
6.A. Date of Application Submittal to Mosquito Vector Control Association	17
6.B. Description of Access for Vector Control Personnel	17
6.C. Mosquito Vector Control Association of California Letter of Verification	18
7. Reliability Information	19
7.A. Estimated Design Life of Device Components before Major Overhaul	19
7.B. Warranty Information	19
7.C. Customer Support Information	19
8. Field/Lab Testing Information and Analysis	20
APPENDIX A	21
APPENDIX B	22
APPENDIX C	23

3. Physical Description

3.A. Trash Capture

The primary component of the CPS that captures trash 5 mm or greater in diameter are stainless steel screens with $\text{Ø}3/16''$ (approximately $\text{Ø}4.8\text{mm}$) round openings. During a storm event the entire design flow is directed through the screens, trapping any trash 5mm or greater in diameter within the catch basin and allowing water to flow past into the outlet pipe. Below is a diagram of the device installed with notes showing how design flow is directed through the device and down towards downstream stormwater infrastructure:

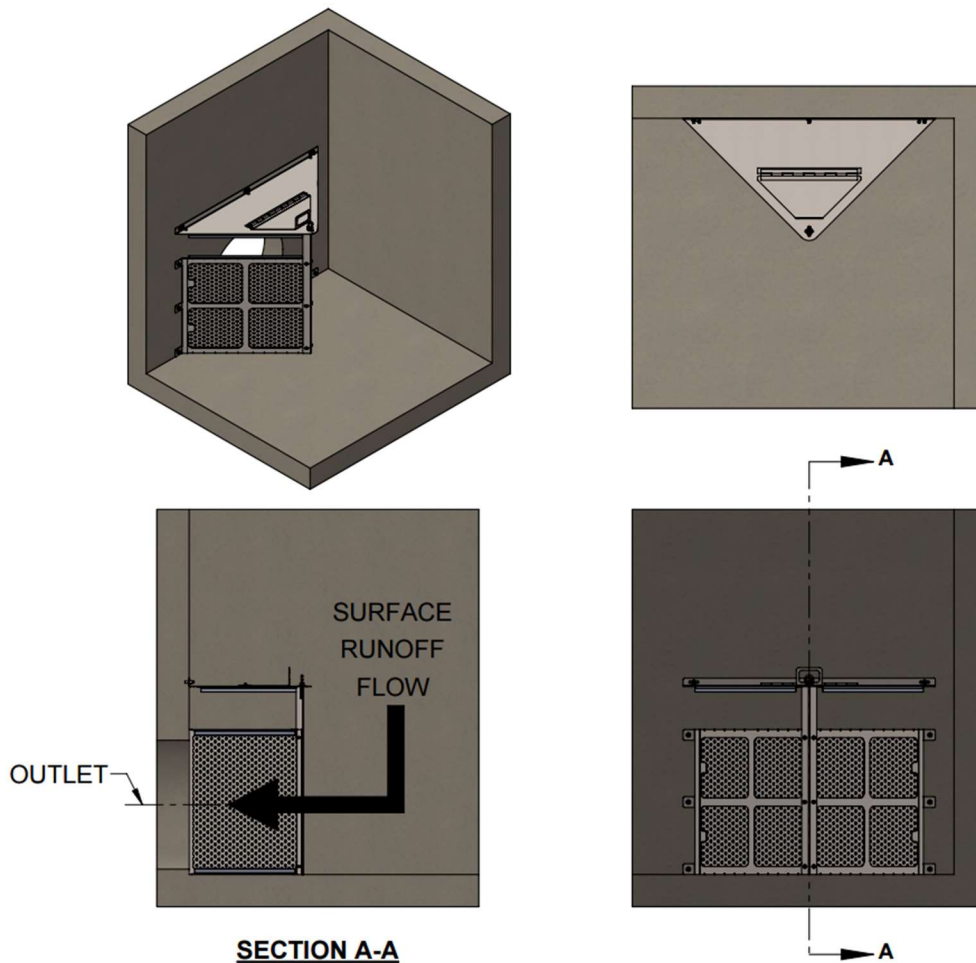

3.B. Peak Flows/Trash Volumes

Please see the tables within Section 3.C. for the hydraulic capacity and recommended max trash storage volume of four common standard size CPS units. Please note there are three configurations of the CPS, a V-shaped configuration with two walls/screens, a U-shape configuration with four walls/screens, and an L-shape configuration with three wall/screens. The CPS can capture trash 5 mm or greater in diameter from surface runoff flowing into an install site up to the max flowrates stated at each trash capacity level for each size of unit. The CPS includes a bypass opening at the top of the device. The screening walls of the CPS thus function as a weir, allowing water to flow over it when a bypass event occurs. Maximum trash volume for the Fabco CPS is equal to the total open volume of the catch basin or vault in which the device is installed with height up to the bypass opening of the CPS.

3.C. Hydraulic Capacity

V-Shape Configuration											
Size	Part #	Width (A)	Depth (B)	Height (C)	Bypass Height (D)	Hydraulic Capacity				Bypass Flow Rate (CFS)	Recommended Max Trash Storage Volume
						Filtered Flow Rate					
						Empty (CFS)	25% Full (CFS)	50% Full (CFS)	75% Full (CFS)		
Ø12" Pipe	OCS12-1TV	25.5"	11"	14"	6"	4	3	2	1	Area of the bypass opening is greater than or equal to outlet pipe open area.	Maximum storage volume will vary with the size of the stormwater structure
Ø18" Pipe	OCS18-1TV	33"	14.5"	20"	7"	11.4	8.6	5.7	2.9		
Ø24" Pipe	OCS24-1TV	48"	22"	33"	8"	20.3	15.2	10.2	5.1		
Ø36" Pipe	OCS36-1TV	54.5"	25"	40"	9"	31.1	23.3	15.6	7.8		

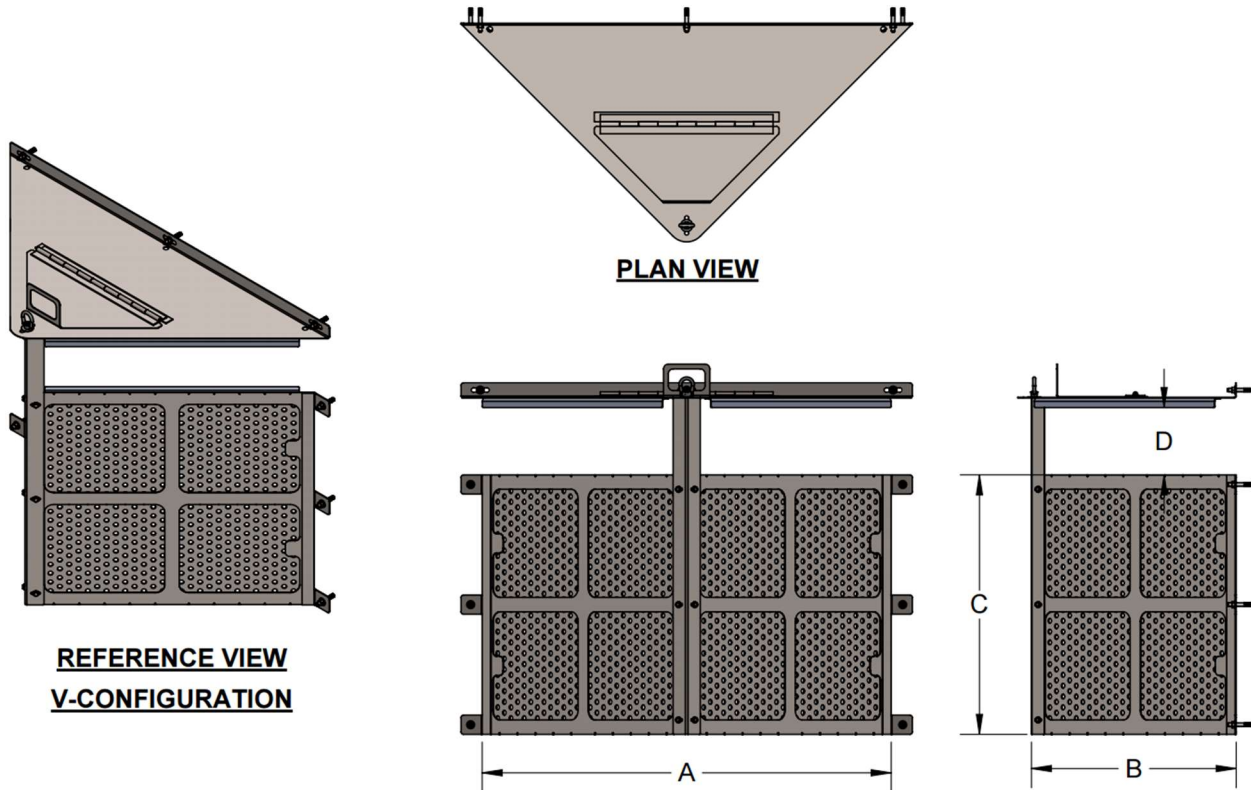

U-Shape Configuration

Size	Part #	Width (A)	Depth (B)	Height (C)	Min. Bypass Height (D)	Hydraulic Capacity					Recommended Max Trash Storage Volume
						Filtered Flow Rate				Bypass Flow Rate (CFS)	
						Empty (CFS)	25% Full (CFS)	50% Full (CFS)	75% Full (CFS)		
Ø12" Pipe	OCS12-1WU	14"	10"	12"	4"	2.8	2.1	1.4	0.7	3.3	Maximum storage volume will vary with the size of the catch basin
Ø18" Pipe	OCS18-1WU	20"	10"	18"	7"	7.3	5.5	3.7	1.8	6.8	
Ø24" Pipe	OCS24-1WU	28"	10"	24"	15"	8.2	6.2	4.1	2.1	17.5	
Ø36" Pipe	OCS30-1WU	40"	10"	36"	20"	18.5	13.9	9.3	4.6	29.3	

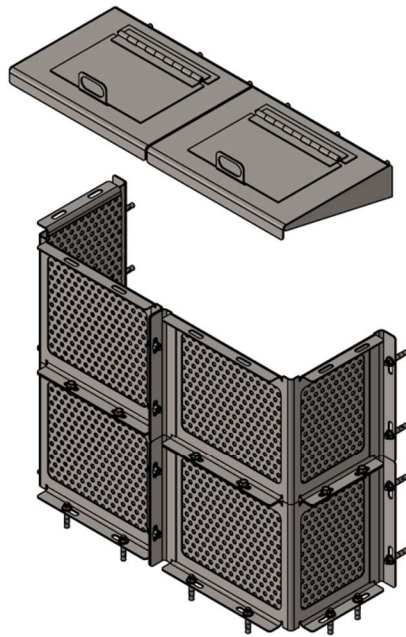

REFERENCE VIEW
U-CONFIGURATION

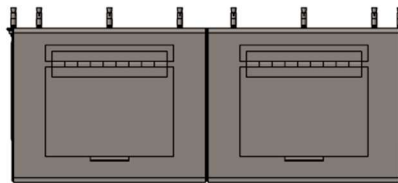

PLAN VIEW

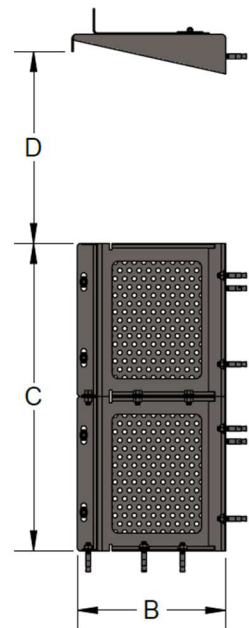
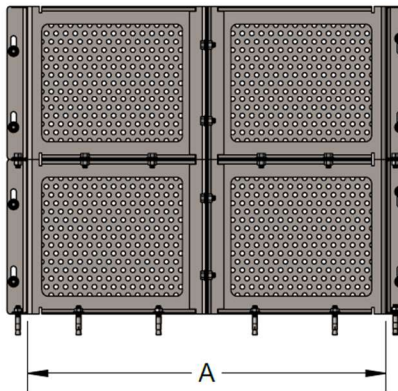
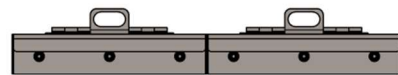

L-Shape Configuration

Size	Part #	Width (A)	Depth (B)	Height (C)	Min. Bypass Height (D)	Hydraulic Capacity					Recommended Max Trash Storage Volume
						Filtered Flow Rate				Bypass Flow Rate (CFS)	
						Empty (CFS)	25% Full (CFS)	50% Full (CFS)	75% Full (CFS)		
Ø12" Pipe	OCS12-1WL	14"	10"	12"	4"	2.0	1.5	1.0	0.5	2.3	Maximum storage volume will vary with the size of the stormwater structure
Ø18" Pipe	OCS18-1WL	20"	10"	18"	7"	5.6	4.2	2.8	1.4	5.1	
Ø24" Pipe	OCS24-1WL	28"	10"	24"	15"	6.6	5.0	3.3	1.7	13.9	
Ø36" Pipe	OCS30-1WL	40"	10"	36"	20"	15.8	11.9	7.9	4.0	24.4	

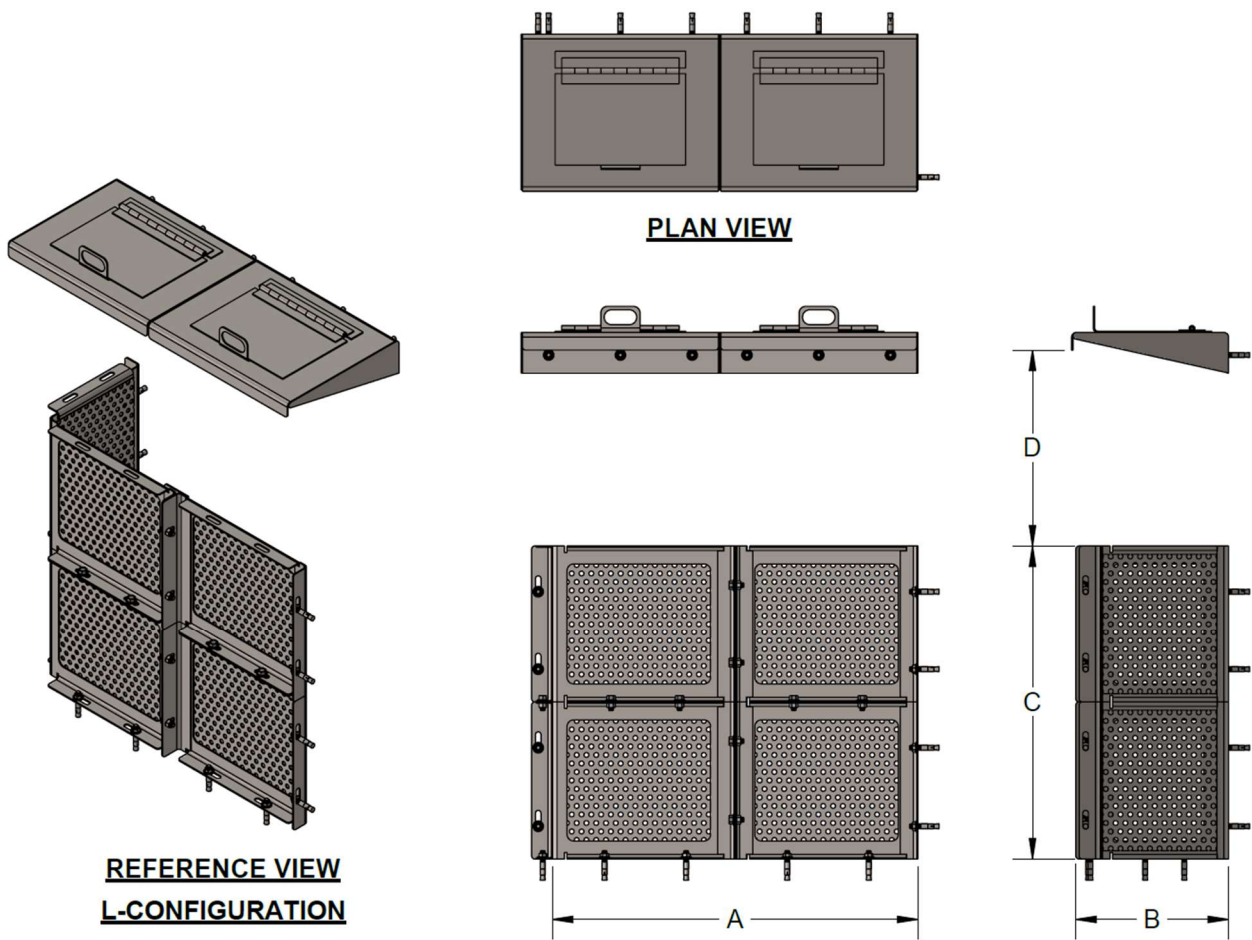

The equation below is used to calculate hydraulic capacity:

$$\text{Orifice Equation: } Q = C_d A \sqrt{2gh}$$

where,

Q = flow rate [in^3/s] *converted to [CFS and GPM]

C_d = coefficient of discharge [0.62 used by Fabco Industries]

A = area of orifice or net open area [in^2] = area of screen [in^2] * % open area

g = acceleration from gravity [in/s^2]

h = head acting on centerline of each screening window [in]

Example Calculation of Empty Filtered Flow Rate for a $\varnothing 24''$ Pipe CPS

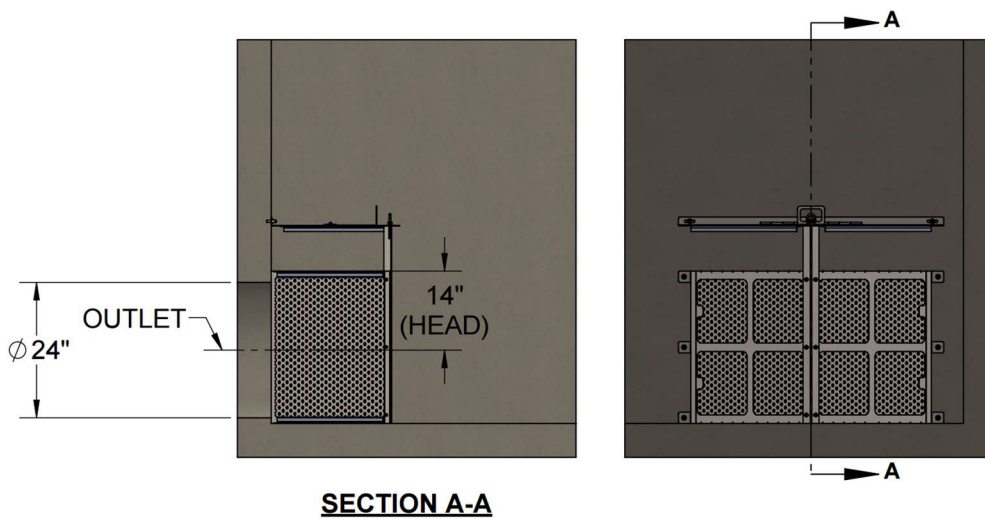

$$Q = (0.62) * (663.27 [\text{in}^2]) * \sqrt{2 * \left(386.4 \left[\frac{\text{in}}{\text{s}^2}\right]\right) * (14 [\text{in}])}$$

$$Q = 42773.97 \left[\frac{\text{in}^3}{\text{s}}\right] \div 1728 \left[\frac{\text{in}^3}{\text{ft}^3}\right]$$

$$Q = 24.75 \left[\frac{\text{ft}^3}{\text{s}}\right]$$

3.D. Comparison Table

Please see Section 3.C. for hydraulic capacity tables for four common sizes of the CPS in V, U, and L Configurations.

3.E. Design Drawings

Please refer to Appendix A for representative design drawings of a $\varnothing 24''$ Pipe CPS unit in V, U, L configurations, and the two options for the U and L configuration: a perforated version of the mandatory top cover, and quick release mounting.

3.F. Optional Components

Fabco's CPS is available in three configurations: (1) a V-Shape configuration, (2) a U-shape configuration, and (3) an L-shape configuration. The V-Shape configuration is designed for sites which require high filtered flow rates. The U and L configurations, however, are designed to fit in tighter spaces. The L configuration additionally allows the device to be installed onto a corner of a catch basin. This is necessary when an adjacent structural wall is too close to the outlet pipe opening and standard installation is not possible. All configurations utilize the same stainless-steel screens with $\text{Ø}3/16''$ (approximately $\text{Ø}4.8\text{mm}$) round openings. As such all configurations function in the same manner however with altered flow rates. Please see the hydraulic capacity table for each configuration provided in Section 3.C.

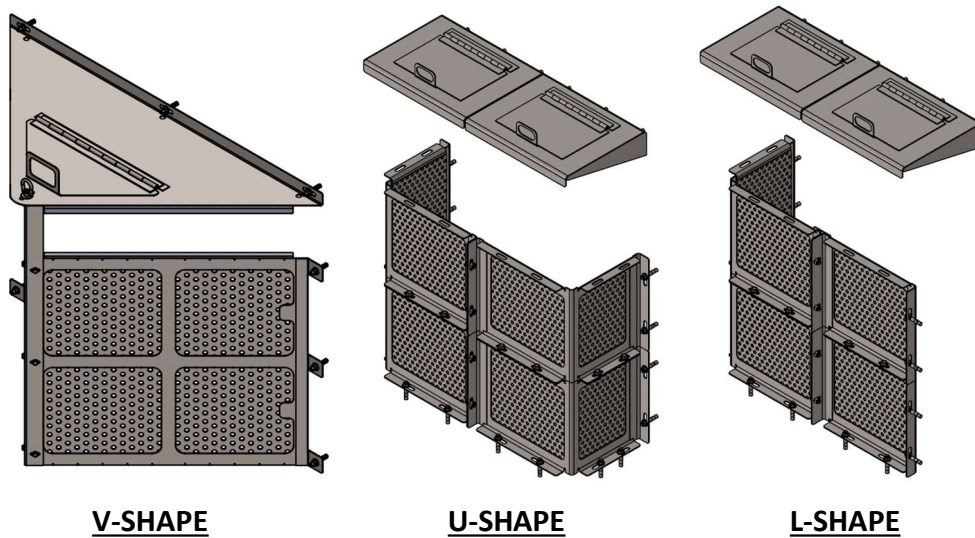

Additionally, there are two optional components for the Fabco CPS U and L-Shape configurations: a perforated version of the mandatory top cover and quick release mounting. The perforated top cover utilizes the same stainless-steel screens with $\text{Ø}3/16''$ (approximately $\text{Ø}4.8\text{mm}$) round openings as the main filter screens. The perforated top cover option allows filtered flow through the top cover, which can be beneficial for some projects during high flow events. However, as the top cover is above the bypass of the CPS it does not change the hydraulic capacity of the Fabco CPS. Vector control access is maintained with no change in the function of the hinged access door.

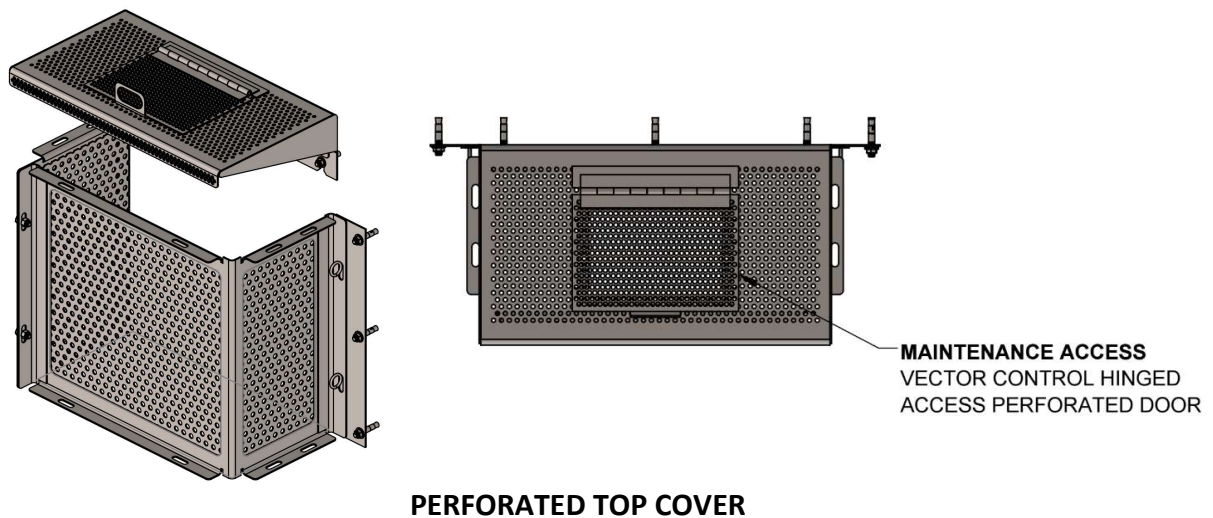

The quick release mounting option for the Fabco CPS utilizes side and top mounting plates which are installed to the catch basin walls using concrete anchors. The mounting plates then allow the CPS filter screen assembly and top cover to be mounted and removed without the need for any tools. The quick release mounting option allows very easy access to each component of the Fabco CPS and to the catch basin outlet for maintenance and inspection. Quick release mounting option does not affect hydraulic capacity of the Fabco CPS.

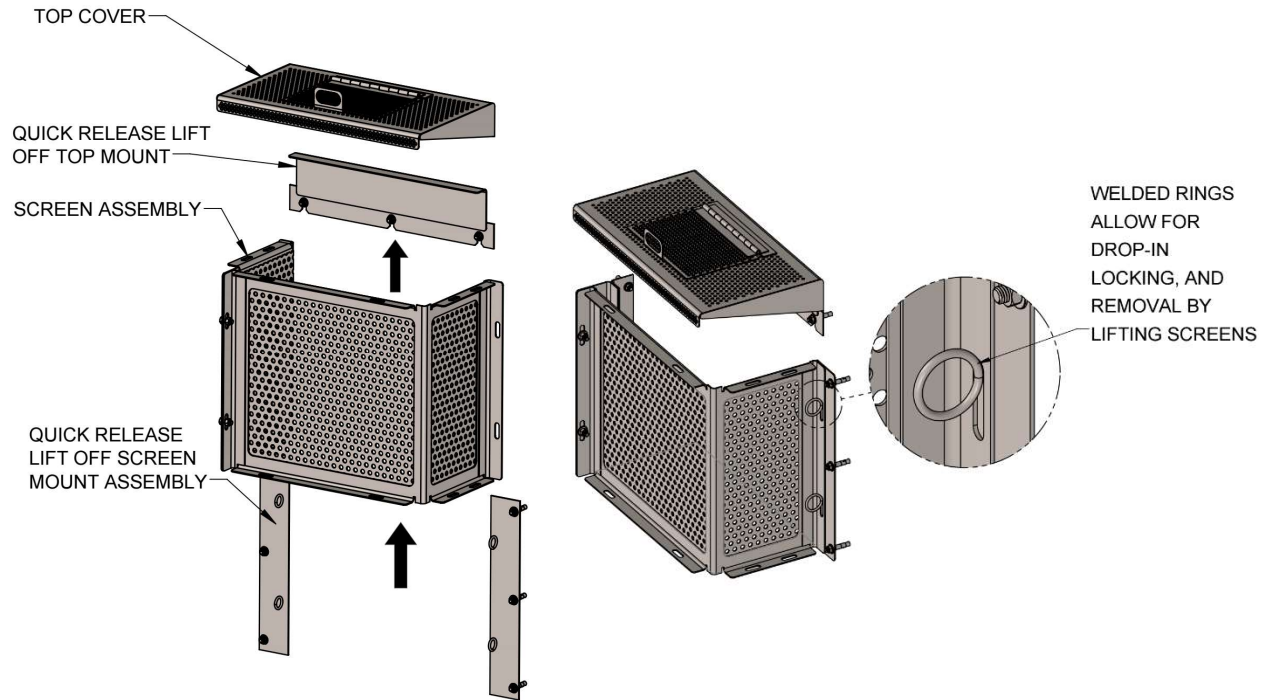

QUICK RELEASE MOUNTING

3.G. Bypass

The bypass of Fabco’s CPS is the opening above the device’s filter screens which allows for unrestricted flow equal to or greater than the outlet pipe. The CPS is engineered to filter at least the trash treatment peak design flow. Thus, the bypass of the Fabco CPS is used only when flow into the catch basin exceeds the peak design flow or when peak flows occur after the device has not been maintained.

3.H. Feeder Troughs

Fabco’s CPS does not include any feeder troughs.

3.I. Calibration Feature

Fabco’s CPS does not include or require any adjustment or calibration.

3.J. Previously Trapped Trash

The only scenario in which previously trapped trash can be re-introduced to the downstream stormwater infrastructure is if there is floating trash which rises above and through the bypass opening when a bypass flow scenario occurs as explained in Section 3.G.

3.K. Material Type

Below is a list of all materials which comprise the CPS and where the materials are used on the device:

- Filter Screens: Stainless-Steel Sheet Metal with \varnothing 3/16" Round Holes
- Frame Assembly: Stainless-Steel Sheet Metal
- (Mandatory) Top Cover, Hinge, and Vector Control Access Door: Stainless-Steel
- Assembly Hardware: Stainless-Steel Hex Bolts, Flat Washers, Lock Washers, and Hex Nuts.
- Mounting Hardware: Steel Concrete Anchors
- Optional Components:
 - Perforated Mandatory Top Cover: Stainless-Steel Sheet Metal with \varnothing 3/16" Round Holes
 - Quick Release Mounting: Stainless-Steel Sheet Metal and Stainless-Steel Rings

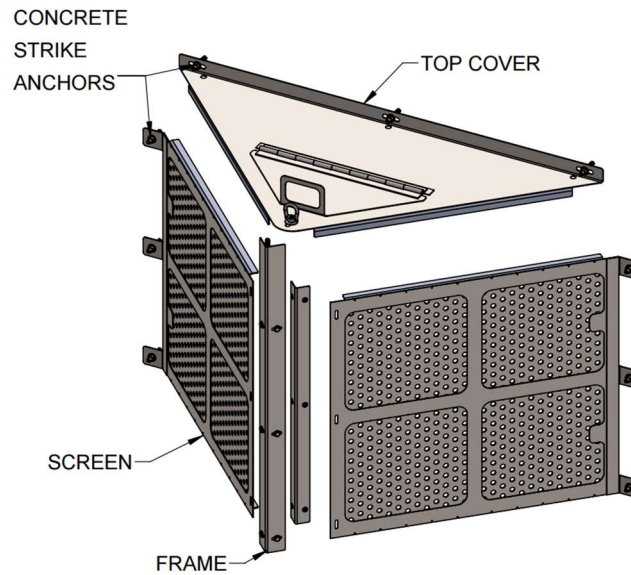

V-CONFIGURATION

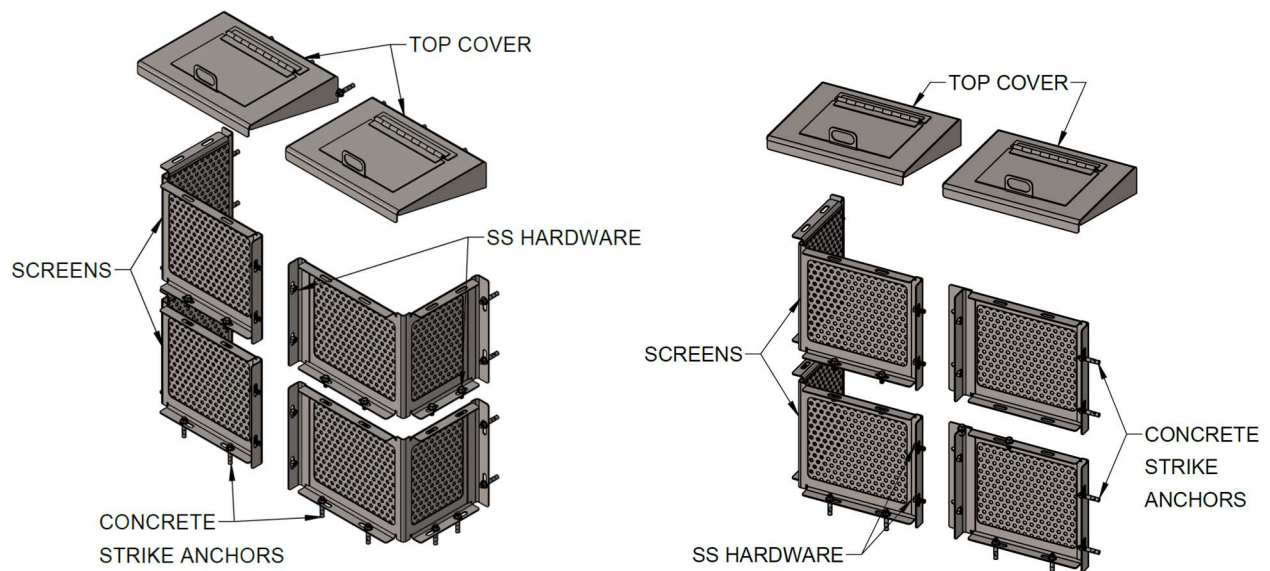

U-CONFIGURATION

L-CONFIGURATION

3.L. Design Life

With expected stormwater conditions and regular maintenance, the CPS has an expected design life of approximately 10 years.

4. Installation Guidance

4.A. Standard Device Installation Procedures and Considerations

General Note: A California Water Board Certified Product Notice is supplied with any purchase of any certified Fabco CPS (See Appendix C). This notice informs installation personnel that proper installation is essential to maintain compliance with the standards set by the California Water Board. During installation no gaps can exceed 5mm (3/16") in width. This stipulation is crucial for maintaining the integrity of the product's performance and adherence to regulatory standards.

Installation should be performed by qualified personnel only. Be sure to follow the proper road safety precautions in accordance with local regulations. Standard installation of a CPS follows the procedure steps below:

Safety: Set up proper safety precautions in accordance with local regulations. Use Traffic Cones to block off the work area. Wear protective gear such as a hard hat, eye protection, kneepads, etc.

1. Unpack, separate, and verify that all the components are accounted for and undamaged. This kit should include the following:
 - Screen Assembly
 - Top Cover with Vector Control Access Door
 - Hardware: Hex Bolts, Hex Nuts, Flat & Lock Washers, and Mounting Anchors
2. Remove any manhole cover to access the curb opening inlet install location.
3. Prepare all catch basin/vault wall surfaces.
4. Pass screens through manhole opening and assemble screen assembly using provided hardware.
5. Position the CPS base screen assembly directly in front of the outlet pipe of the catch basin flush to the wall.
6. Mark holes for provided concrete strike anchors and drill using a masonry drill.
7. Mount the CPS assembly to the catch basin wall using the provided concrete strike anchors.
8. Measure height for bypass, and mark holes for top cover. Drill holes and mount top cover using provided concrete anchors.
9. Ensure that CPS base assembly and top cover are secure in place with no movement.
10. Seal any minor gaps close to the specified limit of 5mm (3/16") that may form when assembling/mounting the Fabco CPS with a suitable caulking compound. *Note do not seal seepage holes located at the bottom of the device.
11. Clear catch basin of all tools and carefully reinstall any grates or manhole covers.

4.B. Description of Device Installation Limitations and Non-Standard Device Installation Procedure

Installation of a Fabco CPS may be limited by existing protrusions within a catch basin. If any non-standard installation is required, the installer should please contact their respective sales representative or Fabco sales support at sales@fabco-industries.com or (631) 393-6024. Installation procedure may differ, but the design of the CPS cannot change.

4.C. Methods for Diagnosing and Correcting Installation Errors

Once the Fabco CPS is installed, ensure a proper installation by performing a visual inspection of the entire installed unit. Confirm the device is centered in front of the outlet pipe, and that mounting points are in firm contact with the vault wall. No gaps during installation can exceed 5 mm (3/16”) in width. If the CPS does not fit securely to the wall, remove, and reinstall again following instructions in Section 4.A. If issues persist, contact Fabco sales support about the issues to further identify possible solutions. If any critical questions at all arise during or after installation, the install team should please contact their respective sales representative or Fabco sales support (Email: sales@fabco-industries.com; Phone: (631) 393-6024) for project specific assistance..

5. Operation and Maintenance Information

5.A. Inspection Procedures and Frequency Considerations

Safety Precautions: The CPS should be inspected by trained individuals who are familiar with local traffic safety regulations and disposal procedures. If working in the street, proper safety equipment should be worn, including but not limited to a hardhat, vest, gloves and eye protection, and all local traffic safety rules & regulations should be followed.

Inspecting the Fabco CPS: To maintain the efficiency of the CPS, regular maintenance is necessary. Fabco Industries advises inspecting the unit every six months, following the steps outlined below. It's important to note that inspection and cleaning should only take place after 24 hours of no rainfall. It's also recommended to periodically examine the surrounding areas for pollutants, such as oil or paint dumping, minor spills, and leaks from dumpsters, and take the appropriate measures to have the source removed.

1. To begin the inspection, remove any catch basin grate or manhole cover to gain visual access to the Fabco CPS install site.
2. Visually inspect all chambers for heavy sediment, trash, and debris loading. A battery powered flashlight or droplight is recommended for thorough inspection.
3. Visually inspect the device for any damage or unfastening that may have occurred.
4. Use a hook tool or equivalent tool to ensure vector control hinged top mandatory deflector screen is easily opened.
5. Measure the trash load using a tape measure or equivalent trash measurement tool.
6. Keep a record of inspection, noting any irregularity, damage, or loss of secure mounting.
7. Record trash load measurement.
8. (If necessary) take photos and keep on record.
9. Perform vector control inspection and keep records.
10. Ensure that the hinged top mandatory deflector screen is in the closed position.
11. Reinstall any removed catch basin grates or manhole covers.

5.B. Description of Maintenance Frequency Considerations

Recurring maintenance is needed to make sure the Fabco CPS can function properly in screening the design flow of the drainage structure in which it's installed. Fabco suggests a minimum maintenance schedule of at least two times a year by removing the trash and debris, sand and silt with a vacuum assisted device. Typically, the maintenance should be scheduled for once at the start of the local rainy season and once at the end of the local rainy season. If there is no defined rainy season, the maintenance can be scheduled equally spaced throughout the year. However, the Municipal Storm Water permit may specify more frequent maintenance intervals. Because the actual trash load on a drain can vary from site to site, the inspection record can be used to properly plan the needed maintenance schedule. To minimize maintenance costs Fabco generally suggests that the clean outs take place any time the device is at 50% full trash capacity.

5.C. Maintenance Procedures

Safety Precautions: The CPS should be inspected by trained individuals who are familiar with local traffic safety regulations and disposal procedures. If working in the street, proper safety equipment should be worn, including but not limited to a hardhat, vest, gloves and eye protection, and all local traffic safety rules & regulations should be followed.

1. Remove the catch basin grate or manhole access cover and set safely to the side of the drainage access point.
2. Visually inspect all chambers for heavy sediment, trash, and debris loading. A battery powered flashlight or droplight is recommended for thorough inspection.
3. Remove the sediment, trash, and debris from the system. This can be done manually by hand with shovels and buckets, however for large scale implementation the most efficient method is to use a vacuum system such as a Vactor truck.
4. Visually inspect the device after cleaning and record any damage or unfastening of the device.
5. If deemed necessary, a power washer can be used to clean the system further.
6. If no critical issues are present or any concerns remain, reinstall any removed grates or manhole covers.
7. All liquid, oils, sediment, debris, trash and other accumulated items removed from the catch basin must be handled and disposed of in accordance with local, state and federal regulations.

Disposal: Proper handling and disposal of all captured liquid, oils, sediment, debris, trash, and other accumulations from the Fabco CPS must comply with local, state, and federal regulations. As part of a well-planned and scheduled maintenance regime, disposal considerations should be considered. Generally, solid waste disposal can be arranged with a local landfill, while liquid waste can be disposed of at either a wastewater treatment plant or a municipal vacuum truck decant facility.

5.D. Essential Equipment and Materials for Proper Maintenance Activities

Fabco Industries recommends the following equipment for maintenance of the Fabco CPS:

- Proper safety equipment including but not limited to hard hats, safety vests, gloves, kneepads, and eye protection.
- Any required traffic control equipment.
- A battery powered flashlight or drop light.
- Shovels and buckets or industrial vacuum.
- Pressure washer (optional).
- Manhole cover removal/reinstallation tools.

5.E. Description of the Effects of Deferred Maintenance on Device Structural Integrity, Performance, Odors, Etc.

If maintenance is deferred for the Fabco CPS, the full trash and debris capacity of the Fabco CPS can be reached causing a bypass event when a rainstorm occurs. During a bypass event, floating trash will flow past the Fabco CPS system and discharge into any downstream stormwater infrastructure or water body. Deferred maintenance will not affect the structural integrity of the Fabco CPS.

5.F. Repair Procedures for Device's Structural and Screening Components

If during inspection or maintenance of the Fabco CPS it's found that the device needs repair, photographs and documentation should be sent to the Fabco assistance team at: sales@fabco-industries.com. The Fabco engineering and technical support team can then assess the damage and suggest a repair plan or begin a warranty repair or replacement.

6. Vector Control Accessibility

6.A. Date of Application Submittal to Mosquito Vector Control Association

Application to the Mosquito and Vector Control Association of California (MVCAC) for the Fabco CPS was submitted on July 29th, 2024, and letter of verification was received on August 7th, 2024. Please see Appendix B for the MVCAC verification letter.

6.B. Description of Access for Vector Control Personnel

The Fabco CPS includes a mandatory lightweight hinged top cover allowing for easy access by Vector Control personnel without requiring any confined space entry. The mandatory hinged top deflector screen has a lifting tab that can be grabbed with a hook tool or equivalent tool to flip the cover open or closed. When the top cover is open, the space behind the CPS is available for inspection, or treatment by Vector Control personnel. With feedback from MVCAC, Fabco has also made sure to include seepage holes between the bottom of the device and the bottom of the basin. This feature ensures that standing water will not build up.

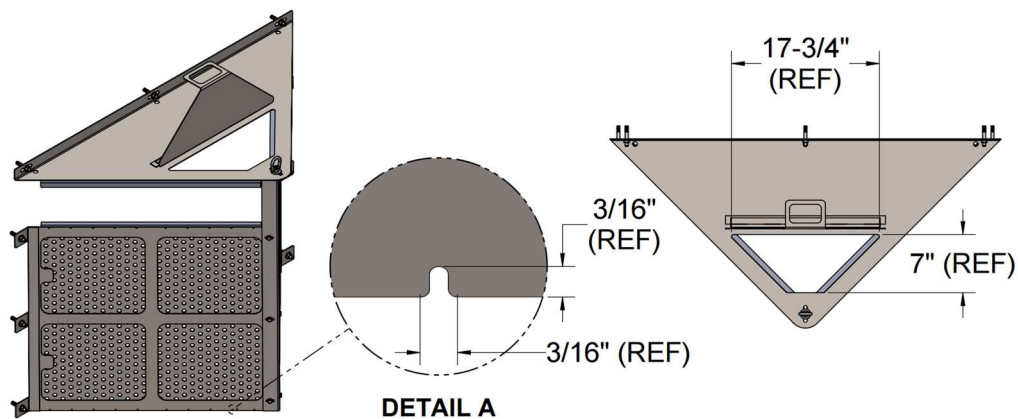

V-CONFIGURATION

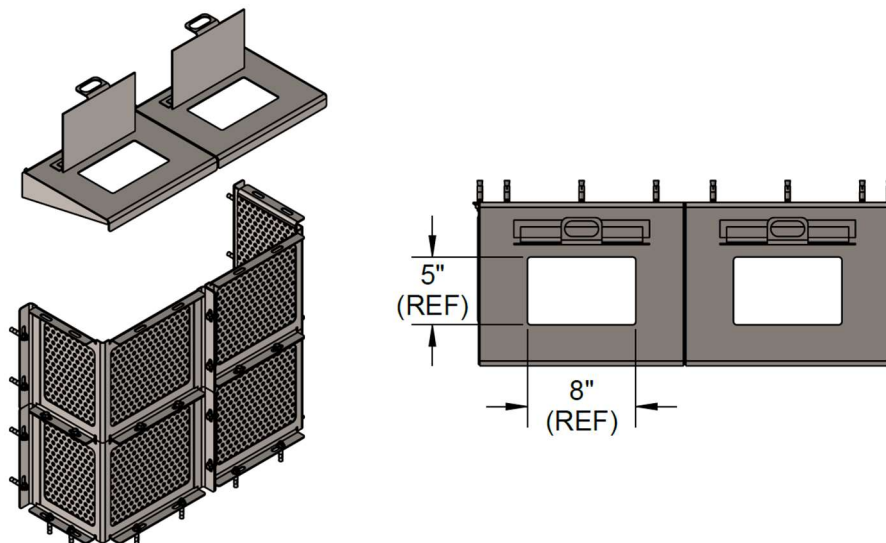

U-CONFIGURATION

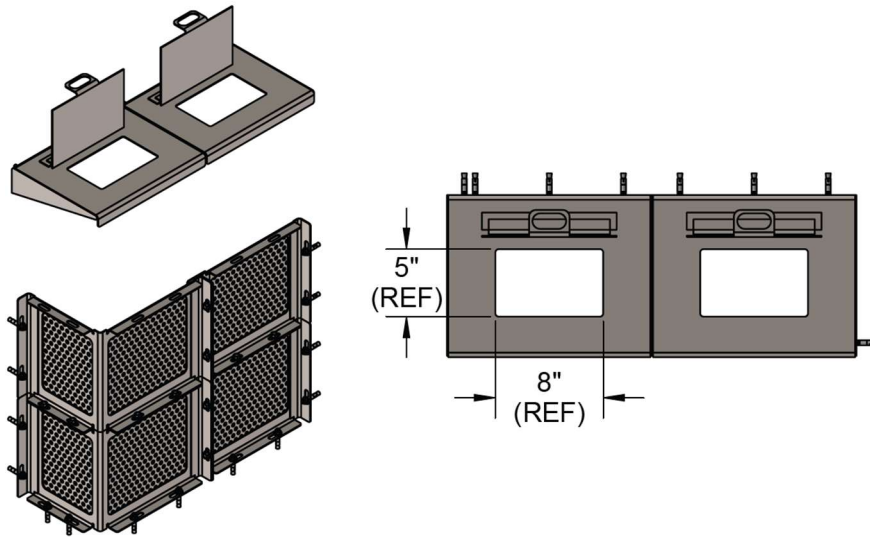

L-CONFIGURATION

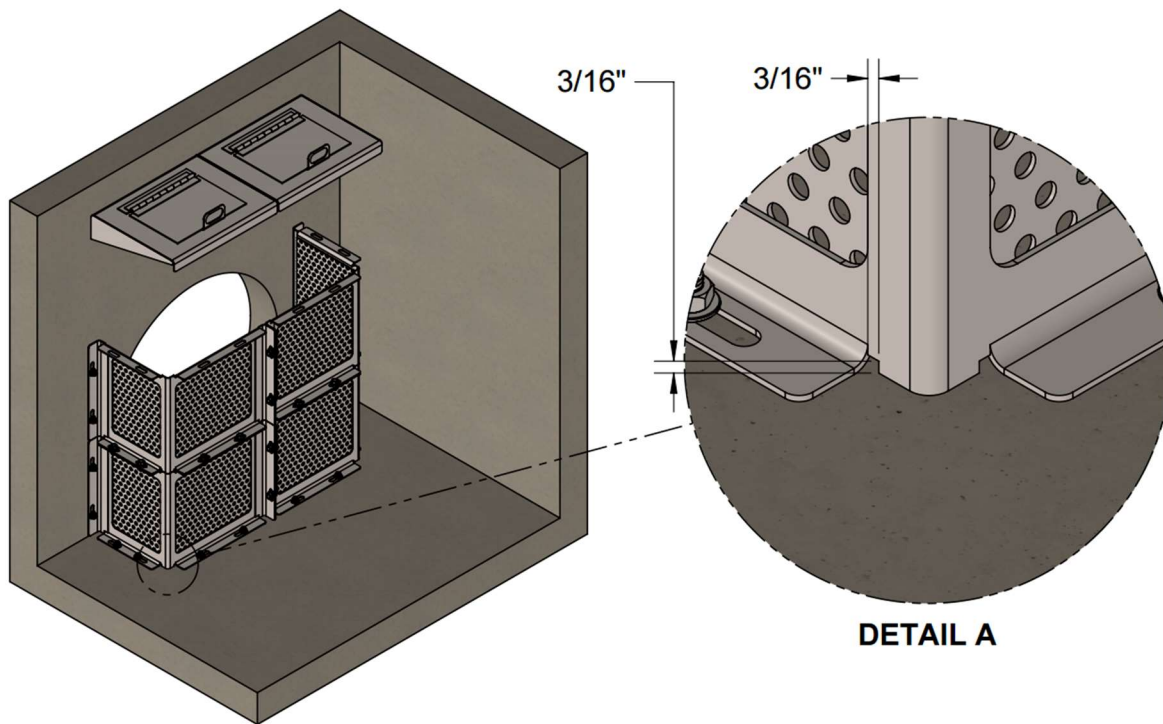

DETAIL A

SEEPAGE HOLES

6.C. Mosquito Vector Control Association of California Letter of Verification

Please refer to Appendix B to find the MVCAC letter of verification for the Fabco CPS.

7. Reliability Information

7.A. Estimated Design Life of Device Components before Major Overhaul

The life expectancy of the Fabco CPS is estimated by consideration of the materials used to fabricate the Fabco CPS. With expected stormwater conditions and regular maintenance, the Fabco CPS has an estimated design life of 10 years.

7.B. Warranty Information

Fabco Industries, Inc., warrants that the Fabco CPS shall be free from defects in materials and workmanship for a period of 10 years from the date of delivery. The warranty coverage requires that the products must be installed in accordance with all site conditions required by state and local codes, applicable product or industry specifications and guidelines, manufacturer's installation recommendations and other applicable laws. Specifically excluded from the warranty are damages arising from ordinary wear and tear, alteration, or repair by anyone other than Fabco Industries, Inc. or under the direction of Fabco Industries Inc. Furthermore, damage due to accident, misuse, abuse or neglect, or any other event not caused by Fabco Industries Inc, is also not covered by the warranty.

If a warranty claim is made and determined to be valid, Fabco Industries Inc. will either repair or replace the product, solely at the discretion of Fabco Industries, Inc. All warranty claims must be submitted, evaluated, and approved by Fabco Industries, Inc., for the claim to be determined to be valid. There are no other warranties either expressed or implied other than what is specifically specified herein.

7.C. Customer Support Information

Fabco customer support can provide technical information and help with any questions regarding Fabco Industries' products. You can reach our customer support service at:

Fabco Industries, Inc.

390 Oser Avenue

Hauppauge, NY 11788

Phone: (631) 393-6024

Email: sales@fabco-industries.com

Website: fabco-industries.com

8. Field/Lab Testing Information and Analysis

All sizes and configurations of the Fabco CPS utilize a screen with $\text{Ø}3/16''$ holes (approximately 4.8 mm). Field/Lab testing is not required for the Fabco CPS. This is because all treated design flow must pass through these screens with 4.8mm holes to enter the outlet pipe, and all particles 5mm in diameter and greater within the treatment flow will be physically blocked from passing through. Existing installations of the Fabco CPS, including project sites in California, have yielded only positive results.

APPENDIX A

NOTES

1. WEIGHT (EST.):
 1. 75 LBS
2. MATERIAL:
 1. SCREEN: 304 STAINLESS STEEL, 3/16" HOLES, 51% OPEN
 2. FRAME: 304 STAINLESS STEEL
 3. HARDWARE: STAINLESS STEEL
3. PERFORMANCE:
 1. TREATED FLOW RATE: 9,100 GPM (20.3 CFS)
 2. SCREEN OPEN AREA ≥ OUTLET PIPE AREA
 3. BYPASS FLOW RATE: 5,025 GPM (11.2 CFS)
 4. BYPASS AREA ≥ OUTLET PIPE AREA
4. INSTALLATION:

LOOSELY ASSEMBLE THE BASE ASSEMBLY USING THE PROVIDED BOLTS AND WASHERS. POSITION THE CPS BASE AGAINST THE CATCH BASIN WALL AND IN FRONT OF THE OUTLET PIPE. MOUNT USING THE PROVIDED CONCRETE STRIKE ANCHORS. TIGHTEN HARDWARE. PLACE TOP COVER ON BASE, USE EYE-NUT TO SECURE TOP COVER TO BASE. MOUNT TO CATCH BASIN WALL USING PROVIDED STRIKE ANCHORS.
5. FEATURES:
 1. CA WATERBOARD VECTOR CONTROL ACCESS DOOR ALLOWS INSPECTION WITHOUT ENTERING CATCH BASIN

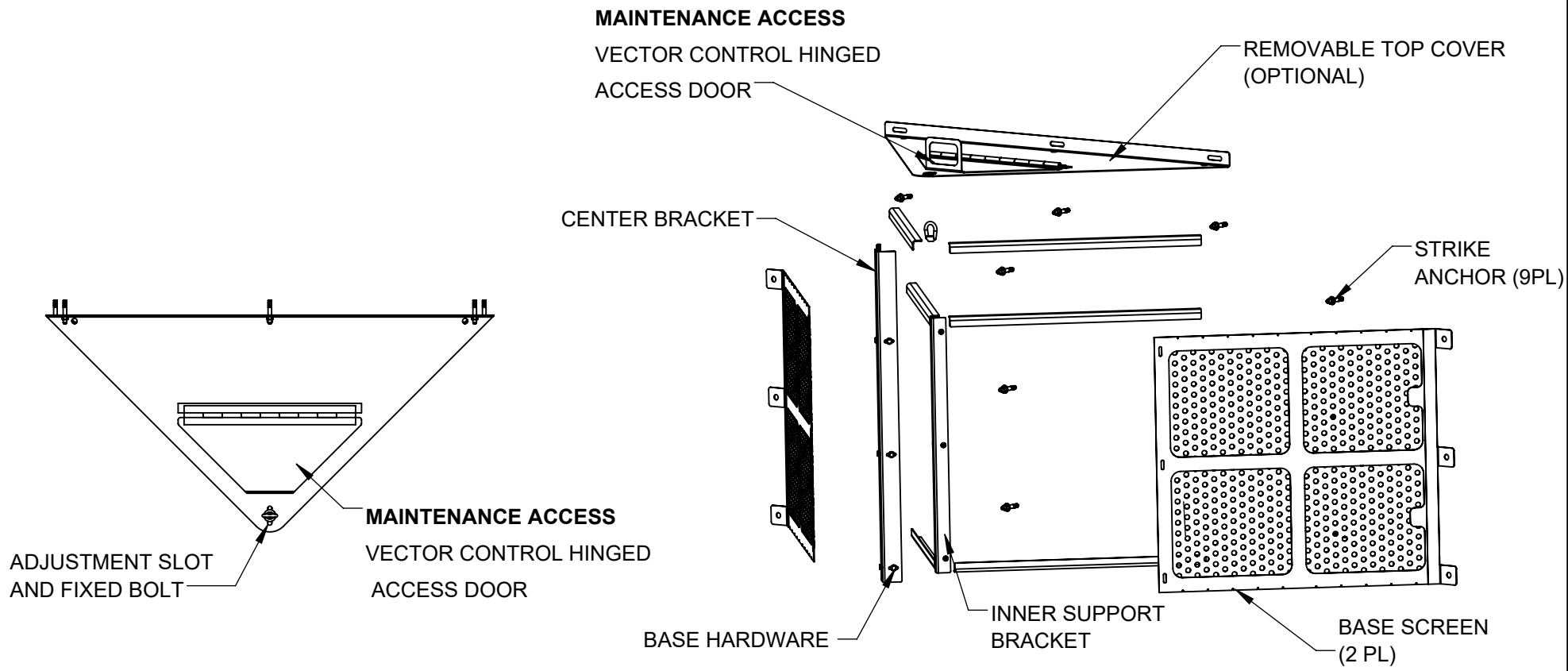

**REFERENCE VIEW
(EXPLODED)**

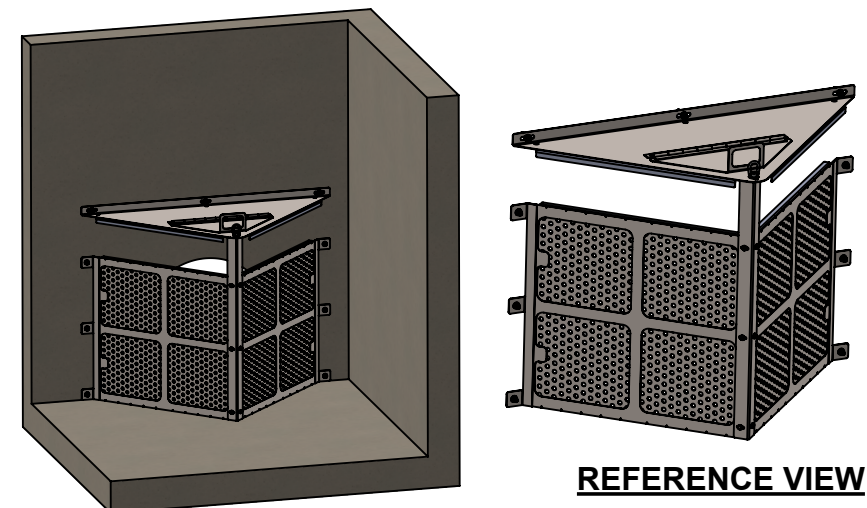
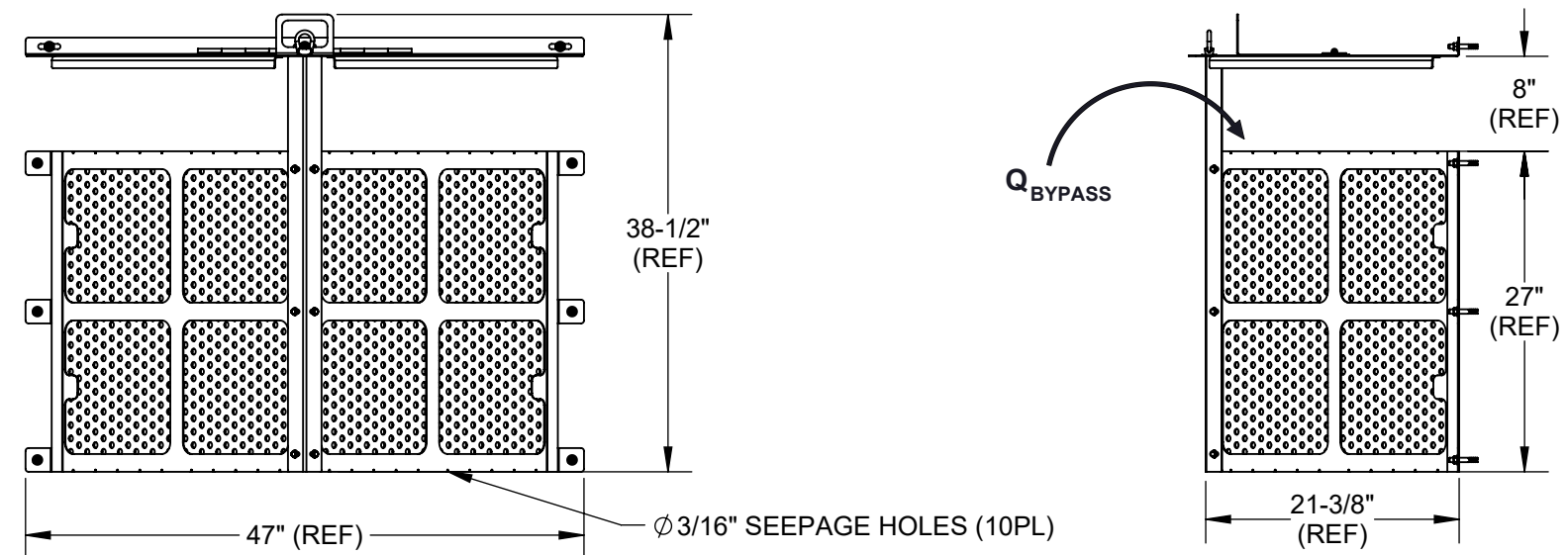

REFERENCE VIEW

**REFERENCE VIEW
(IN VAULT)**



ENGINEER AND CONTRACTOR NOTE: FABCO INDUSTRIES WATER QUALITY INSERTS (WQIS) ARE MANUFACTURED TO PROPERLY FIT INLETS BY USING SPECIFIC INFORMATION COMPILED IN A SURVEY OF THE "AS-BUILT" INLET. IN RETROFIT SITUATIONS THE SURVEY IS DONE TO DOCUMENT THE THREE CRITICAL ASPECTS OF WQI DESIGN (GRATE/FRAME MEASUREMENTS, OPEN/CLEAR SPACE MEASUREMENTS, AND PROTRUSION MEASUREMENTS). IN NEW CONSTRUCTION, FABCO PRODUCT DRAWINGS ARE ESSENTIALLY PLACE HOLDERS BASED ON THE SPECIFIED INLETS. ONCE THE INLETS ARE BUILT, THE PROCESS REVERTS TO THE RETROFIT APPROACH OF SURVEYING THE AS-BUILT INLETS TO CONFIRM FABCO INSERT DESIGN. PLEASE USE THE QR CODE TO ACCESS THE SURVEY FORM AND COMPREHENSIVE GUIDANCE OF THE SURVEY PROCESS. ALTERNATIVELY, NAVIGATE TO www.fabco-industries.com/stormwater-inlet-survey-assistance

PROPRIETARY AND CONFIDENTIAL
THIS DOCUMENT IS THE PROPERTY OF FABCO INDUSTRIES AND IS CONVEYED WITH THE EXPRESS CONDITION THAT IT AND THE INFORMATION CONTAINED IN IT ARE NOT TO BE USED, DISCLOSED, OR REPRODUCED IN WHOLE OR IN PART, FOR ANY PURPOSE WITHOUT THE EXPRESS WRITTEN CONSENT OF FABCO INDUSTRIES; AND THAT NO RIGHT IS GRANTED TO DISCLOSE OR SO USE ANY INFORMATION CONTAINED IN SAID DOCUMENT.

UNLESS OTHERWISE SPECIFIED
REMOVE ALL BURRS
BREAK SHARP EDGES .002 - .020
FILLETS .020 MAX
DIMENSIONS ARE IN INCHES AND INCLUDE CHEMICALLY APPLIED OR PLATED FINISHES

TOLERANCES:
DEC .00 ± .01
DEC .000 ± .005
FRACT ± 1/16
ANGLE ± 2°

PROJECT: SEE NOTES

APPROVAL	DATE
DWN J.C.	2/8/2023
CHKR J.P.	2/8/2023
UPD J.C.	5/2/2023

FABCO INDUSTRIES, INC.
24 CENTRAL DRIVE
FARMINGDALE, NY 11735
WWW.FABCO-INDUSTRIES.COM

fabco
Industries Inc.

**CPS LITE
FOR 24" OUTLET**

SIZE	DWG. NO.	REV
B	OCS24-1TV-000	C

SCALE: NONE SHEET 1 OF 1

NOTES:

1. MATERIAL:

- A. STAINLESS STEEL FRAME & HARDWARE
- B. PERFORATED STAINLESS STEEL, ϕ 5mm HOLES
- C. PERFORATED SCREEN, 51% OPEN AREA

2. CUSTOM SIZES AVAILABLE, CONTACT FERGUSON WATERWORKS

3. WARRANTY: 10-YEARS ON MANUFACTURED COMPONENTS
(REFER TO FABCO WEBSITE FOR FURTHER DETAILS)

4. TYPICAL INSTALLATION:

- A. PASS SCREENS THROUGH MANHOLE OPENING AND ASSEMBLE SCREEN ASSEMBLY USING PROVIDED HARDWARE.
- B. POSITION CPS BASE AGAINST CATCH BASIN WALL IN FRONT OF OUTLET PIPE.
- C. MOUNT USING PROVIDED CONCRETE ANCHORS AND SEAL EDGES WITH SILICONE IF NECESSARY.
- D. MEASURE HEIGHT FOR BYPASS AND MOUNT COVER USING PROVIDED CONCRETE ANCHORS

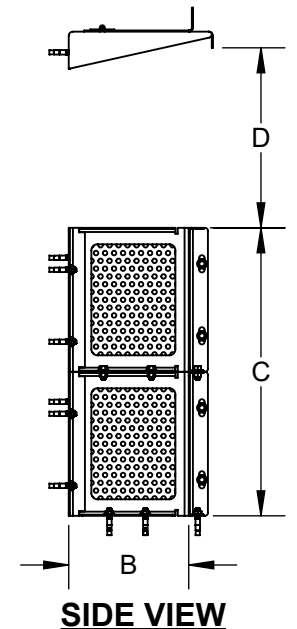
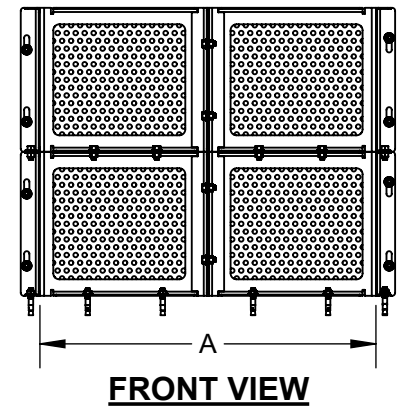
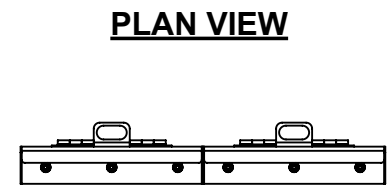
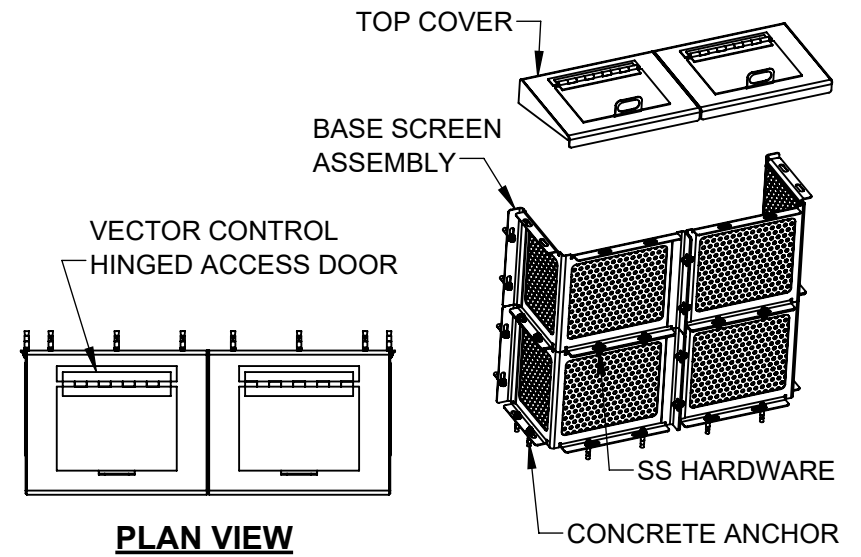

CERTIFIED FULL TRASH CAPTURE DEVICE BY CALIFORNIA STATE WATERBOARD

PART NUMBER	PIPE DIA.	WIDTH (A)	DEPTH (B)	HEIGHT (C)	MIN. BYPASS HEIGHT (D)	FILTERED FLOW RATE	BYPASS FLOW RATE
OCS12-1WU	12	14"	10"	12"	4"	2.8 CFS	3.3 CFS
OCS18-1WU	18	20"	10"	18"	7"	7.3 CFS	6.8 CFS
OCS24-1WU	24	28"	10"	24"	15"	8.2 CFS	17.5 CFS
OCS36-1WU	36	40"	10"	36"	20"	18.5 CFS	29.3 CFS



NOT TO SCALE

12/18/2023

CPS, U-WALL-MOUNTED

NOTES:

1. MATERIAL:

- A. STAINLESS STEEL FRAME & HARDWARE
- B. PERFORATED STAINLESS STEEL, ϕ 5mm HOLES
- C. PERFORATED SCREEN, 51% OPEN AREA

2. CUSTOM SIZES AVAILABLE, CONTACT FERGUSON WATERWORKS

3. WARRANTY: 10-YEARS ON MANUFACTURED COMPONENTS (REFER TO FABCO WEBSITE FOR FURTHER DETAILS)

4. TYPICAL INSTALLATION:

- A. PASS SCREENS THROUGH MANHOLE OPENING AND ASSEMBLE SCREEN ASSEMBLY USING PROVIDED HARDWARE.
- B. POSITION CPS BASE AGAINST CATCH BASIN WALL IN FRONT OF OUTLET PIPE.
- C. MOUNT USING PROVIDED CONCRETE ANCHORS AND SEAL EDGES WITH SILICONE IF NECESSARY.
- D. MEASURE HEIGHT FOR BYPASS AND MOUNT COVER USING PROVIDED CONCRETE ANCHORS

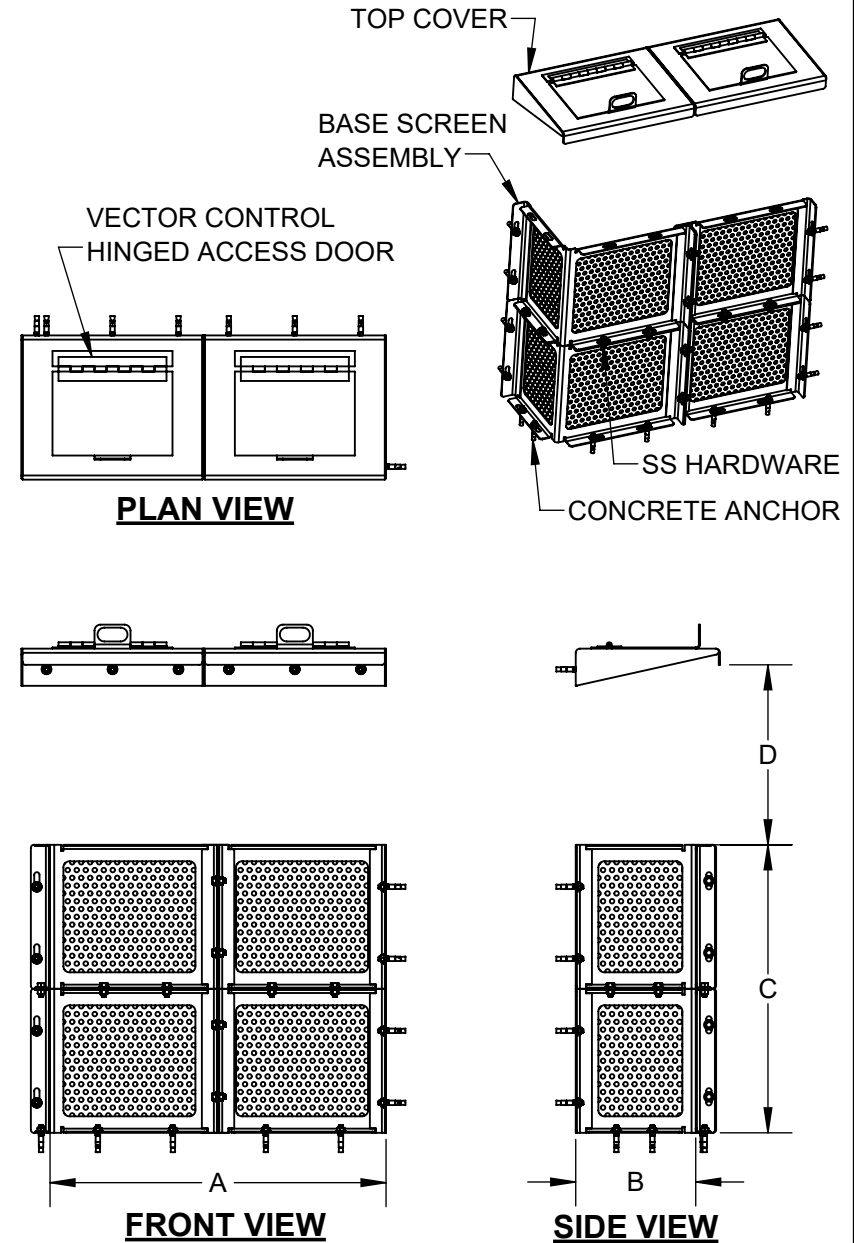

CERTIFIED FULL TRASH CAPTURE DEVICE BY CALIFORNIA STATE WATERBOARD

PART NUMBER	PIPE DIA.	WIDTH (A)	DEPTH (B)	HEIGHT (C)	MIN. BYPASS HEIGHT (D)	FILTERED FLOW RATE	BYPASS FLOW RATE
OCS12-1WL	12	14"	10"	12"	4"	2.0 CFS	2.3 CFS
OCS18-1WL	18	20"	10"	18"	7"	5.6 CFS	5.1 CFS
OCS24-1WL	24	28"	10"	24"	15"	6.6 CFS	13.9 CFS
OCS36-1WL	36	40"	10"	36"	20"	15.8 CFS	24.4 CFS



NOT TO SCALE

12/18/2023

CPS, L-WALL-MOUNTED

NOTES:

1. WEIGHT (EST): 47 LBS MAX

2. MATERIAL:

- A. FRAME: 300 SERIES STAINLESS STEEL
- B. PERFORATED SCREEN 300 SERIES STAINLESS STEEL, 5mm HOLES, 51% OPEN AREA
- C. HARDWARE: STAINLESS STEEL

3. PERFORMANCE CHARACTERISTICS (TYP):

- A. FILTERED FLOW RATE: 7.3 CFS
- B. BYPASS FLOW RATE: 6.8 CFS

4. WARRANTY: 10-YEARS ON MANUFACTURED COMPONENTS

(REFER TO FABCO WEBSITE FOR FURTHER DETAILS)

5. TYPICAL INSTALLATION:

- A. PASS SCREENS THROUGH MANHOLE OPENING AND ASSEMBLE SCREEN ASSEMBLY USING PROVIDED HARDWARE.
- B. POSITION CPS BASE AGAINST CATCH BASIN WALL IN FRONT OF OUTLET PIPE.
- C. MOUNT QUICK RELEASE MOUNTS USING PROVIDED CONCRETE ANCHORS
- D. MEASURE HEIGHT FOR BYPASS AND MOUNT QUICK RELEASE COVER ASSEMBLY USING PROVIDED CONCRETE ANCHORS.
- E. LIFT SCREEN ASSEMBLY APPROXIMATELY 1" UP TO RELEASE FROM LIFT OFF HINGES FOR OUTLET PIPE ACCESS.

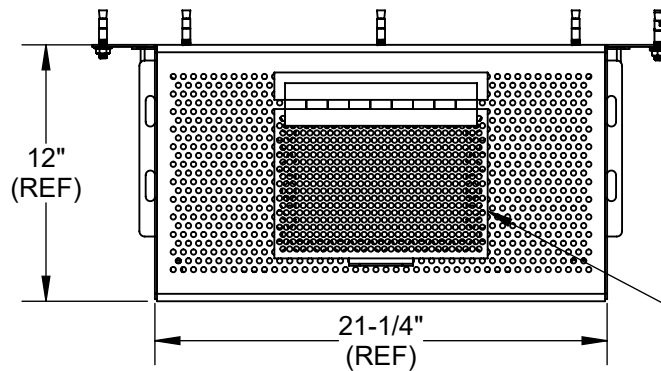

MAINTENANCE ACCESS
VECTOR CONTROL HINGED
ACCESS PERFORATED DOOR

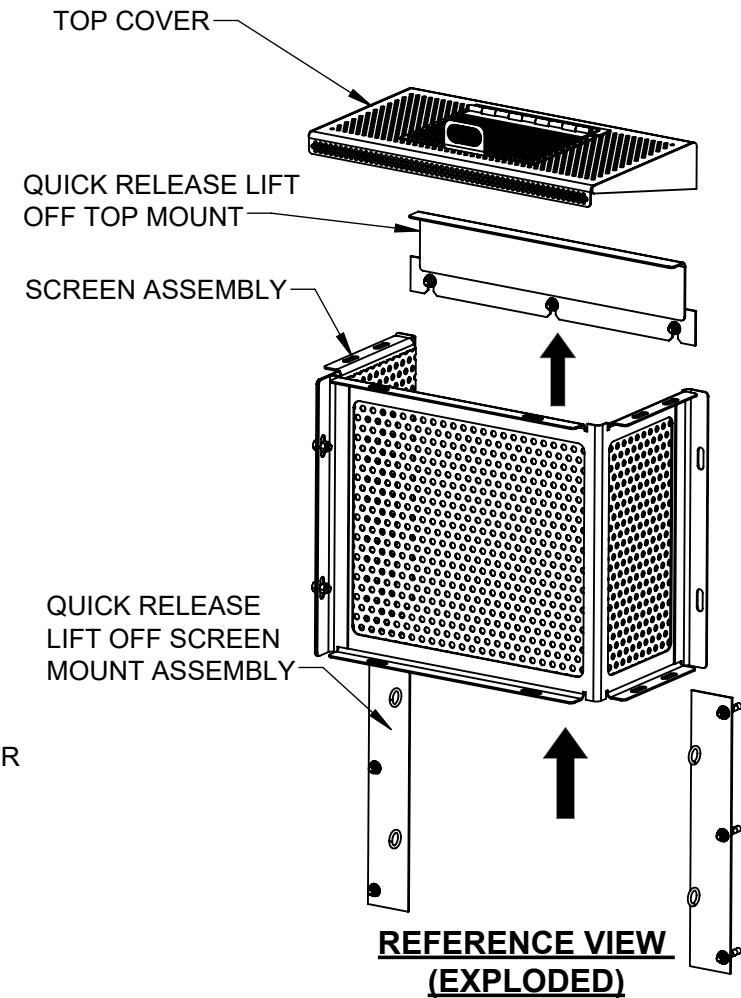

**REFERENCE VIEW
(EXPLODED)**

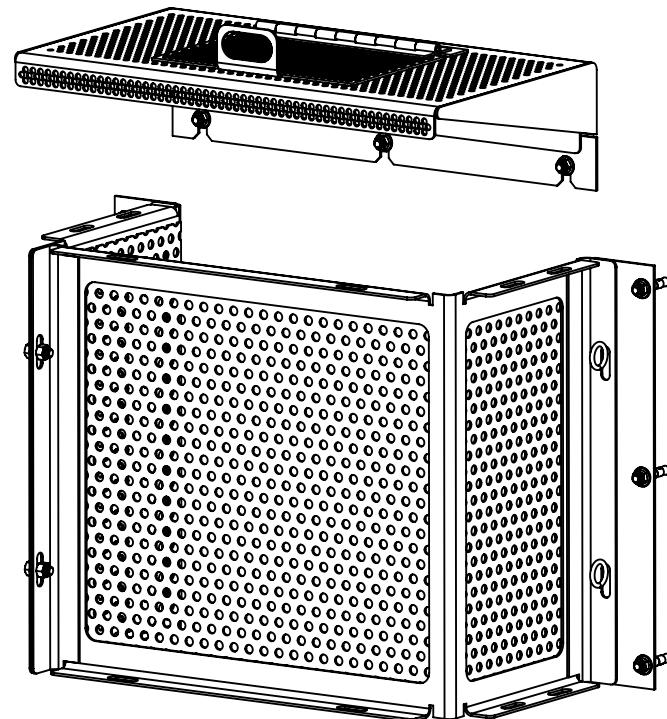

REFERENCE VIEW

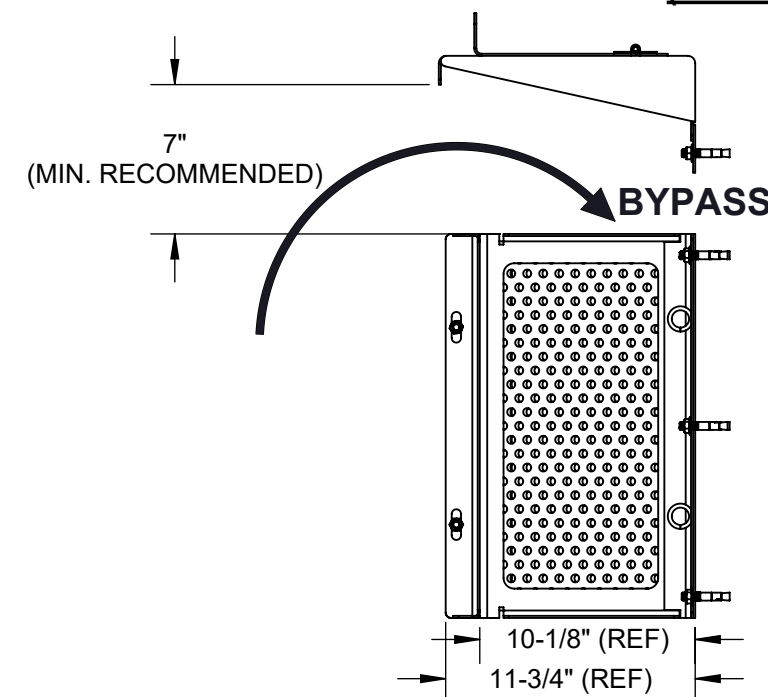
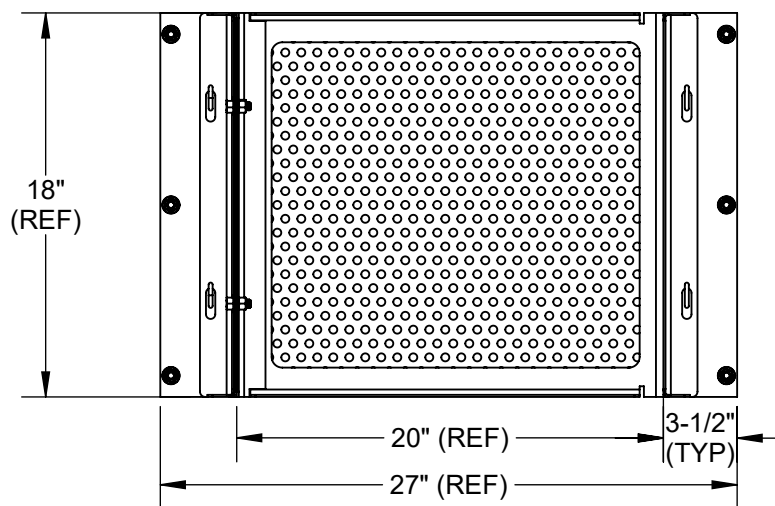
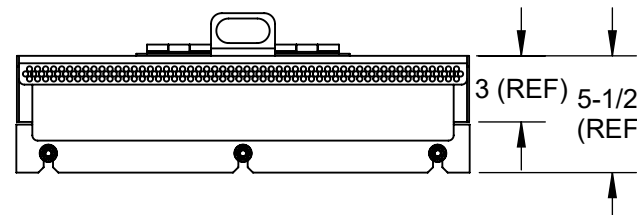

WARRANTY DETAILS	SURVEY GUIDANCE

ENGINEER AND CONTRACTOR NOTE: FABCO INDUSTRIES WATER QUALITY INSERTS (WQIS) ARE MANUFACTURED TO PROPERLY FIT INLETS BY USING SPECIFIC INFORMATION COMPILED IN A SURVEY OF THE "AS-BUILT" INLET. IN RETROFIT SITUATIONS THE SURVEY IS DONE TO DOCUMENT THE THREE CRITICAL ASPECTS OF WQI DESIGN (GRATE/FRAME MEASUREMENTS, OPEN/CLEAR SPACE MEASUREMENTS, AND PROTRUSION MEASUREMENTS). IN NEW CONSTRUCTION, FABCO PRODUCT DRAWINGS ARE ESSENTIALLY PLACE HOLDERS BASED ON THE SPECIFIED INLETS. ONCE THE INLETS ARE BUILT, THE PROCESS REVERTS TO THE RETROFIT APPROACH OF SURVEYING THE AS-BUILT INLETS TO CONFIRM FABCO INSERT DESIGN. PLEASE USE THE QR CODE TO ACCESS THE SURVEY FORM AND COMPREHENSIVE GUIDANCE OF THE SURVEY PROCESS. ALTERNATIVELY, NAVIGATE TO www.fabco-industries.com/stormwater-inlet-survey-assistance

PROPRIETARY AND CONFIDENTIAL
THIS DOCUMENT IS THE PROPERTY OF FABCO INDUSTRIES AND IS CONVEYED WITH THE EXPRESS CONDITION THAT IT AND THE INFORMATION CONTAINED IN IT ARE NOT TO BE USED, DISCLOSED, OR REPRODUCED IN WHOLE OR IN PART, FOR ANY PURPOSE WITHOUT THE EXPRESS WRITTEN CONSENT OF FABCO INDUSTRIES; AND THAT NO RIGHT IS GRANTED TO DISCLOSE OR SO USE ANY INFORMATION CONTAINED IN SAID DOCUMENT.

UNLESS OTHERWISE SPECIFIED REMOVE ALL BURRS BREAK SHARP EDGES .002 - .020 FILLETS .020 MAX DIMENSIONS ARE IN INCHES AND INCLUDE CHEMICALLY APPLIED OR PLATED FINISHES		TOLERANCES: DEC .00 ± .01 DEC .000 ± .005 FRACT ± 1/16 ANGLE ± 2°		APPROVAL	DATE
PROJECT		FABCO INDUSTRIES, INC. 24 CENTRAL DRIVE FARMINGDALE, NY 11735 WWW.FABCO-INDUSTRIES.COM		DWN CHKR ENGR UPD	J.C. J.P. 1/4/2024
MATERIAL		SEE NOTES		18" CPS-U VECTOR CONTROL AND QUICK RELEASE	
SCALE: NONE		SIZE DWG. NO. B OCS18-1WUQ-000		REV A	
SHEET 1 OF 1					



APPENDIX B

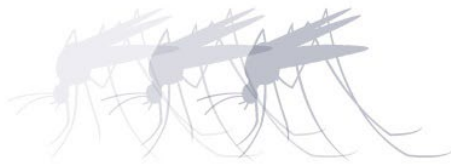

MVCAC
Mosquito and Vector Control Association of California

One Capitol Mall, Suite 320 • Sacramento, CA 95814 • p: (916) 440-0826 • f: (916) 444-7462 • e: mvcac@mvcac.org

Mr. Hime Athar
Fabco Industries, Inc
390 Oser Avenue.
Hauppauge, NY 11788

August 7, 2024

Dear Mr. Athar,

Thank you for the submission of the Fabco Connector Pipe Screen full trash capture device for review by the Mosquito and Vector Control Association of California pursuant to the SWRCB Trash Treatment Control Device Application Requirements. The Association has reviewed the conceptual drawings for the revised Fabco Connector Pipe Screen, configurations L, U, and V, and verifies that provisions have been included in the designs that allow for full visual access to all areas for presence of standing water, and when necessary, allows for treatments of mosquitoes.

While this verification letter confirms that inspection and treatment for the purpose of minimizing mosquito production should be possible with the revised Fabco Connector Pipe Screen as presented, it does not affect the local mosquito control agency's rights and remedies under the State Mosquito Abatement and Vector Control District Law. For example, if the installed device or the associated stormwater system infrastructure becomes a mosquito breeding source, it may be determined by a local mosquito control agency to be a public nuisance in accordance with California Health and Safety Code sections 2060-2067.

"Public nuisance" means any of the following:

1. Any property, excluding water, that has been artificially altered from its natural condition so that it now supports the development, attraction, or harborage of vectors. The presence of vectors in their developmental stages on a property is prima facie evidence that the property is a public nuisance.
2. Any water that is a breeding place for vectors. The presence of vectors in their developmental stages in the water is prima facie evidence that the water is a public nuisance.
3. Any activity that supports the development, attraction, or harborage of vectors, or that facilitates the introduction or spread of vectors. (Heal. & Saf. Code § 2002 (j).)

Declaration of a facility or property as a public nuisance may result in penalties as provided under the Health and Safety Code. Municipalities and the vendors they work with are encouraged to discuss the design, installation, and maintenance of stormwater trash capture devices with their local mosquito control agency to reduce the potential for disease transmission and public nuisance associated with mosquito production.

Sincerely,

Megan MacNee
MVCAC Executive Director

APPENDIX C



**** Important Installation Notice ****

This is a California Water Board Certified Product

Dear Valued Customer,

We are pleased to inform you that your recent purchase from Fabco Industries, Inc. has been carefully manufactured and inspected to meet the rigorous standards set forth by the California Water Board. As a company committed to environmental stewardship and regulatory compliance, we take great pride in delivering products that not only meet but exceed industry requirements.

It is imperative to note that the proper installation of our products is essential for maintaining compliance with the standards set by the California Water Board. Therefore, we urge you to ensure that during installation, any gaps do not exceed 5mm (3/16") in width. This stipulation is crucial for maintaining the integrity of the product's performance and adherence to regulatory standards.

In the rare event that a gap larger than 5mm (3/16") is encountered after installation, we kindly request that you promptly contact Fabco Industries. Our dedicated team will work diligently to resolve any issues and ensure your complete satisfaction with our product.

Furthermore, please be aware that minor gaps close to the specified limit of 5mm (3/16") can be easily remedied on-site with a suitable caulking compound. This proactive measure will help to maintain the integrity of the installation and uphold compliance with regulatory requirements.

At Fabco Industries, we are committed to providing high-quality products and exceptional customer service. Should you have any questions or concerns regarding your recent purchase or the installation process, please do not hesitate to contact our customer support team.

Thank you for choosing Fabco Industries for your stormwater management needs. We appreciate your business and look forward to serving you again in the future.

Sincerely yours,
Team Fabco

Fabco Industries, Inc.
390 Oser Ave. Unit B
Hauppauge, NY 11788
Phone: 631.393.6024
Email: sales@fabco-industries.com