



November 6, 2024

Mr. Leo Cosentini
California State Water Resources Control Board
Division of Water Quality
P.O. Box 100
Sacramento, CA, 95812-100

Re: Trash Treatment Control Device Application for ADS Full Trash Capture (FTC) Inserts

Dear Mr. Cosentini,

Thank you for the opportunity for Advanced Drainage Systems, Inc. to submit the following revision to our application for the ADS FTC Full Trash Capture Inserts with Vector Control enhancements (Application 3) as a Trash Full Capture System.

The following updates and improvements have been made and are being submitted for approval:

1. Contact information and manufacturer's website
2. Hydraulic capacity and comparison information
3. Screen flow and bypass flow calculations
4. Design drawings
5. Installation guidance
6. Maintenance information
7. Warranty
8. Customer support information

While our hydraulic calculations have changed, we improved our methodology and have not changed our product design. There is no change to vector control access.

Thank you for your time to review this application. If any additional information is required, please contact me.

Regards,

Amanda Toth

Amanda Toth
Product Manager, Water Quality
Advanced Drainage Systems, Inc

1. COVER LETTER

A. Device Product Name & General Description

The ADS Full Trash Capture (FTC) Insert is an engineered, custom manufactured catch basin inlet filter manufactured by the FlexStorm division of Advanced Drainage Systems (ADS). It is placed directly under a catch basin drainage grate or suspended below a catch basin curb opening to collect trash and debris from surface storm water runoff.

B. Applicant's Contact Information and Location

The device is manufactured by Advanced Drainage Systems™

Executive Contact at Corporate Headquarters:
Joseph Chylik, Product Director for Water Treatment
4640 Trueman Blvd
Hilliard, OH 43026
(800) 821-6710
joseph.chylik@adspipe.com

Authorized Representative(s) Contact Information:
Amanda Toth, Product Manager, Treatment
4640 Trueman Blvd
Hilliard, OH 43026
(614) 202-3723
amanda.toth@adspipe.com

Contact at Manufacturing Facility:
Eric Butler, Site Manager, ADS FlexStorm
24137 111th Street, unit A
Naperville, IL, 60564
Ph. 630-453-4934
eric.butler@adspipe.com

C. Manufacturer's Website Page for Device

<https://www.adspipe.com/water-management-solutions/water-quality/pretreatment/flexstorm-full-trash-capture-inlet-filter>

D. Device's Manufacturing Location

Advanced Drainage Systems - FlexStorm
24137 111th Street – Unit A
Naperville, IL 60564

E. Brief Summary of Field/Lab Testing Results

No field/lab testing has been performed.

The ADS FTC is constructed of perforated stainless steel with round punched 3/16" (5mm) openings, ensuring particles larger than 5mm cannot pass through.

F. Description or list of locations, if any, where Device has been installed

Thousands of ADS FTC have been successfully installed throughout California and the United States. Below are some recent California installations:

Project	Contact
Camarillo	Robert Carr robertc@downstreamservices.com 760-746-2544
San Diego	Gregg Brenner gergg@waterwerx.com 858-397-1001

G. If the System is designed to operate outside of a typical stormwater catch basin and is able to trap trash from high flows, indicate a preference to be listed as a high flow capacity System on the State Water Board’s website.

Do not list as “high flow capacity trash full capture system”.

H. Certification Clause

I certify under penalty of law that this document and all attachments were prepared under my direction or supervision in accordance with a system designed to assure that qualified personnel properly gather and evaluate the information submitted. Based on my inquiry of the person or persons that manage the system or those persons directly responsible for gathering the information, to the best of my knowledge and belief, the information submitted is, true, accurate, and complete. I am aware that there are significant penalties for submitting false information, including the possibility of fine and imprisonment for knowing violations.

Amanda Toth, Product Manager, Treatment
Advanced Drainage Systems, Inc
ADS FlexStorm Division

2. Table of Contents

1. Cover Letter	1
a. Device Product Name & General Description	1
b. Applicant's Contact Information and Location	1
c. Manufacturer's Website Page for Device	1
d. Device's Manufacturing Location	1
e. Brief Summary of Field/Lab Testing Results	1
f. Description or list of locations, if any, where Device has been installed	2
g. High flow capacity trash full capture system designation	2
h. Certification Clause	2
2. Table of Contents	3-4
3. Physical Description	5-12
a. Trash Capture	5
b. Peak Flows/Trash Volumes	5
c. Hydraulic Capacity	6-10
d. Comparison Table	11
e. Design drawings	11
f. Optional Components	11
g. Internal Bypass	11
h. Feeder Troughs	11
i. Calibration Feature	11
j. Previously Trapped Trash	12
k. Photographs, if any, of Pre- and Post-Installation Examples	12
l. Material Type	12
m. Design Life	12
4. Installation Guidance	13
a. Standard Device Installation Procedures and Considerations	13
b. Description of Device Installation Limitations and/or Non-Standard Device Installation Procedures	13
c. Methods for Diagnosing and Correcting Installation Errors	13
5. Operation and Maintenance Information	13-15
a. Device Inspection Procedures and Inspection Frequency Considerations	13
b. Maintenance Frequency	14
c. Maintenance Procedures	14
d. Essential Equipment and Materials for Proper Maintenance Activities	14
e. Description of the Effects of Deferred Maintenance on Device Structural Integrity, Performance, Odors, etc.	14
f. Repair Procedures for the Device's Structural and Screening Components	15
6. Vector Control Accessibility	15-16
a. Description of Vector Control Accessibility	15
b. System Drawings of Vector Control Accessibility	15
c. Date of Application Submittal to Mosquito Vector Control Association	16
d. Mosquito Vector Control Association of California Letter of Verification	16

7. Reliability Information	16
a. Estimated Design Life of Device Components Before Major Overhaul	16
b. Warranty Information	16
c. Customer Support Information.....	16
8. Field/Lab Testing Information Analysis.....	17
a. For devices with 5mm Screening, any Available Field/Lab Testing Information that Demonstrated the Device Functionality and Performance	17

Appendices

APPENDIX A - Design Drawings	18-21
APPENDIX B – Vector Control Verification Letter	22-23

3. Physical Description

A. Trash Capture

The ADS FTC device is a drop in device installed within the catch basin by resting the filter frame on the grate ledge. It is comprised of 304 stainless steel, using 5mm perforated screen which blocks all solids, trash and debris larger than 5mm from moving past the screen, retaining them in the filter basket.

See Appendix A for detailed drawings.

B. Peak Flows/Trash Volumes

ADS FTC devices are fabricated to fit varying grate and curb inlet sizes. The size and volume of the basket are adjusted accordingly for the dimensions of the inlet having larger baskets in the larger inlets. Refer to Tables 3.1 – 3.3 in section 3.C. for hydraulic capacity pertaining to treated and bypass flows.

C. Hydraulic Capacity for Drop-in FTC Inserts

TABLE 3.1 - Hydraulic Capacity Square/Rectangle FTC					
Model	CATCH BASIN OPENING PERIMETER	STORAGE CAPACITY	TREATED FLOW AT EMPTY	TREATED FLOW AT 50% CAPACITY	BYPASS FLOW RATE
	IN	ft ³	CFS	CFS	CFS
62SHDFTC	<64"	0.8	6.8	1.9	1.7
62MHDFTC	65" - 96"	1.6	9.9	2.7	2.6
62LHDFTC	97" - 119"	3.4	16.1	3.9	3.8
62XLHDFTC	>120"	5.4	22.2	5.0	5.2
ADS FTC with Vector Control Option					
62HD18FTC-VC	18 x 18	1.6	9.9	2.7	2.6
62HD24FTC-VC	24 x 24	3.1	15.1	3.7	3.9
62HD3618FTC-VC	36 x 18	3.2	16.6	4.2	4.8
62HD3624FTC-VC	36 x 24	4.8	20.8	4.8	5.3
62HD36FTC-VC	36 x 36	6.4	27.9	5.8	9.6

*Bypass values based on driving head for 4" standing water over a 2" thick grate. Values are not inclusive of treated flow through perforated basket

TABLE 3.2 - Hydraulic Capacity Round FTC					
Model	CATCH BASIN OPENING DIAMETER	STORAGE CAPACITY	TREATED FLOW AT EMPTY	TREATED FLOW AT 50% CAPACITY	BYPASS FLOW RATE
	IN	ft ³	CFS	CFS	CFS
62SHDRFTC	12" - 16"	0.5	4.9	0.8	1.7
62MHDRFTC	17" - 24"	1.6	9.4	1.6	2.5
62LHDRFTC	25" - 26"	2.8	16.2	3.4	3.7
ADS FTC for Nyloplast Basins					
6212NYFTC	12"	0.5	4.8	1.4	1.3
6215NYFTC	15"	0.9	6.5	1.8	1.7
6218NYFTC	18"	1.4	8.4	2.2	2.1
6224NYFTC	24"	2.5	12.3	3.0	2.9
6230NYFTC	30"	4.2	17.2	3.9	3.7

*Bypass values based on driving head for 4" standing water over a 2" thick grate. Values are not inclusive of treated flow through perforated basket

TABLE 3.3 - Hydraulic Capacity Wall Mount FTC				
Model	OPEN THROAT WIDTH	STORAGE CAPACITY	TREATED FLOW AT EMPTY	TREATED FLOW AT 50% CAPACITY
	ft	ft ³	CFS	CFS
62HDWM1FTC	1' - 4' Width (1-Piece Set)	0.9	7.1	2.0
62HDWM2FTC	4' - 8' Width (2-Piece Set)	3.7	20.3	5.2
62HDWM3FTC	8' - 12' Width (3-Piece Set)	7.3	37.8	9.5
62HDWM4FTC	12' - 16' Width (4-Piece Set)	11.0	55.4	13.7

Screen Flow Calculations:

Model:

Treatment flow rate can be calculated using an orifice flow calculation accounting for upstream head. Screen flows are to be published with a safety factor of two accounting for a clogging factor of up to 50% prior to maintenance.

$$Q_{treated} = C_d A_{open} \sqrt{2gh}$$

Equation C.1: Model of Treated Flow Rate

Assumptions:

- Perforated sheet has uniform 5mm (0.127") perforations
- Water at STP
- $g = 32.2 \text{ ft/sec}^2$
- $C_d = 0.53$ per LA County Report, 2007

Variables:

$Q_{treated}$ = Screen Flow Rate (CFS)

C_d = Screen Orifice Coefficient of Discharge (*dimensionless, 0.53 per LA County Report 2007*)

A_{open} = Net Open Area of Screen (ft^2)

L_{basket} = Length of FTC basket (*ft; Opening Length – 0.25 ft*)

W_{basket} = Width of FTC basket (*ft; Opening Width – 0.25 ft*)

H_{basket} = Height of FTC basket (*1 ft, constant*)

h = Depth to the centroid of the screen. (*Assumed Max 50% H_{basket} without clogging, 25% when 50% full or clogged*)

g = Acceleration due to Gravity (32.2 ft/s^2)

Example:

Using a 62HD18FTC model screen empty and at 50% capacity prior to reaching bypass mode, treatment flow rate can be calculated for both hydraulic situations.

$$Q_{treated} = C_d A_{open} \sqrt{2gh}$$

Equation 1: Model of Treated Flow Rate**Variables:**

$Q_{treated}$ = Screen Flow Rate (CFS)

C_d = Screen Orifice Coefficient of Discharge (*dimensionless, 0.53 per LA County Report 2007*)

A_{open} = Net Open Area of Screen (ft^2)

L_{basket} = Length of FTC basket (ft ; 1.25 ft)

W_{basket} = Width of FTC basket (ft ; 1.25 ft)

H_{basket} = Height of FTC basket (ft , 1 ft)

h = Depth to the centroid of the screen. (Assumed Max 50% H_{basket} without clogging, 25% when 50% full or clogged)

g = Acceleration due to Gravity (32.2 ft/s^2)

To determine maximum treated flow rate, the maximum open area of the FTC basket must be calculated:

$$A_{open,100\%} = [(L_{basket} * W_{basket}) + (L_{basket} * H_{basket} * 2) + (W_{basket} * H_{basket} * 2)] * 0.5$$

Equation 2: Model of Basket Open Area, empty screen

Applying Equation 2:

$$A_{open,100\%} [(1.25 * 1.25) + (1.25 * 1 * 2) + (1.25 * 1 * 2)] * 0.5 = 3.28125 \text{ ft}^2$$

Equation 2a: Calculation of Basket Open Area, empty screen

Applying the results of Equation 2a to Equation 1:

$$Q_{treated,max} = (0.53)(3.28125)\sqrt{2 * 32.2 * 0.5} = 9.88 \text{ CFS}$$

Equation 1a: Calculation of Maximum Treated Flow Rate

To determine the 50% full treated flow rate, the open area of the FTC basket while 50% blinded must be calculated:

$$A_{open,50\%} = [(L_{basket} * H_{basket} * 2) + (W_{basket} * H_{basket} * 2)] * 0.25$$

Equation 3: Model of Basket Open Area, 50% blinded basket

Applying Equation 3:

$$A_{open,50\%} = [(1.25 * 1 * 2) + (1.25 * 1 * 2)] * 0.25 = 1.25 \text{ ft}^2$$

Equation 3a: Calculation of Basket Open Area, 50% blinded basket

Applying the results of Equation 3a to Equation 1:

$$Q_{treated,max} = (0.53)(1.25)\sqrt{2 * 32.2 * 0.25} = 2.67 \text{ CFS}$$

Equation 1b: Calculation of 50% Full Treated Flow Rate

Bypass Flow Calculations:

Model:

$$dQ_{bypass} = C_d L \sqrt{2gY} dY$$

Equation 4: Model of Bypass Flow Rate

$$Q_{bypass} = Q_{bypass,bearing} + Q_{bypass,non-bearing}$$

Equation 5: Model of Final Bypass Flow Rate

Assumptions:

- Perforated sheet has uniform 5mm (0.127") perforations
- Water at STP
- $g = 32.2 \text{ ft/sec}^2$
- $C_d = 0.53$ per LA County Report, 2007
- 4" of standing water over a 2.5" grate

Variables:

Q_{bypass} = Bypass Flow Rate (CFS)

C_d = Screen Orifice Coefficient of Discharge (*dimensionless, 0.53 per LA County Report 2007*)

L_{bypass} = Length of Bypass Area (*ft; Opening Length – 0.25 ft*)

W_{bypass} = Width of Bypass Area (*ft; Opening Width – 0.25 ft*)

M = Height of Bypass Area (*ft; constant; 0.1042 ft on holding flange side, 0.1875 ft on non-bearing side*)

H = Driving Head (*ft; 4" of standing water, 2.5" thick grate, 3" flange drop = 0.79 ft*)

g = Acceleration due to Gravity (32.2 ft/s^2)

Example:

Using a 62HD18FTC model basket, bypass flow rate can be calculated through the application of the above model.

$$dQ_{bypass} = C_d L \sqrt{2gY} dY$$

Equation 4: Model of Bypass Flow Rate

$$Q_{bypass} = Q_{bypass,bearing} + Q_{bypass,non-bearing}$$

Equation 5: Model of Final Bypass Flow Rate

Q_{bypass} = Bypass Flow Rate (CFS)

C_d = Screen Orifice Coefficient of Discharge (*dimensionless, 0.53 per LA County Report 2007*)

L_{bypass} = Length of Bypass Area (*ft; 1.25 ft*)

W_{bypass} = Width of Bypass Area (*ft; 1.25 ft*)

M = Height of Bypass Area (*ft; constant; 0.1042 ft on holding flange side, 0.1875 ft on non-bearing side*)

H = Driving Head (*ft; 4" of standing water, 2.5" thick grate, 3" flange drop = 0.79 ft*)

g = Acceleration due to Gravity (*32.2 ft/s²*)

To calculate Bypass flow rate, Equation 4 must be applied to all four sides of the bypass area:

$$dQ_{bypass} = C_d L \sqrt{2gY} dY$$

Equation 4: Model of Bypass Flow Rate

Integrating Equation 4 over the height of the orifice:

$$Q_{bypass} = \frac{2}{3} C_d L \sqrt{2g} \left[H^{\frac{3}{2}} - (H - M)^{\frac{3}{2}} \right]$$

Equation 4a: Integrated Model of Bypass Flow Rate

Applying Equation 4a to the load bearing side and multiplying by two:

$$Q_{bypass,bearing} = \frac{4}{3} (0.53)(1.25)\sqrt{2 * 32.2} \left[0.79^{\frac{3}{2}} - (0.79 - 0.1042)^{\frac{3}{2}} \right] = 0.95 \text{ CFS}$$

Equation 4b: Calculation of Bypass Flow Rate for Load-Bearing Side

Applying Equation 4a to the non-load bearing side and multiplying by two:

$$Q_{bypass,bearing} = \frac{4}{3} (0.53)(1.25)\sqrt{2 * 32.2} \left[0.79^{\frac{3}{2}} - (0.79 - 0.1875)^{\frac{3}{2}} \right] = 1.66 \text{ CFS}$$

Equation 4c: Calculation of Bypass Flow Rate for Non-Load Bearing Side

Applying Equations 3, 4, to Equation 2:

$$Q_{bypass} = 1.66 + 0.65 = 2.62 \text{ CFS}$$

Equation 5a: Calculation of Final Bypass Flow Rate

D. Comparison Table

See Table 3.1 - 3.3 in section 3.C. for peak flow rates.

E. Design Drawings for Full Trash Capture Inserts

Engineering drawings for all standard configurations are found in Appendix A. ADS has established a catalog of common sized inserts based on the standard drainage structures found throughout California and the United States. The Installer (Contractor) shall inspect the plans and/or worksite to determine the quantity of each drainage structure casting type. The catch basin design, casting number, or the exact grate and clear opening size will provide the information necessary to identify the required ADS FTC insert part number. Inserts are supplied to the field pre-configured to fit the specified drainage structure.

F. Optional Components

Hinged Flange – A hinged flange and slightly shortened basket are required for Vector Control visual access to the bottom of the catch basin.

Oil Skimmer Pouch – On sites where oil removal is needed, an optional oil skimming pouch can be added to the FTC basket. This pouch is tethered inside the basket such that it floats on the water level within the basket and absorbs hydrocarbon oils. The oil pouch is tethered so it cannot float out of the FTC basket even if the unit enters bypass mode.

G. Internal Bypass

The bypass region of the ADS FTC Insert is located above the perforated filter media. It only becomes active should the basket become filled and blinded with storm water, trash, and debris. In these cases, the water spills over the side of the perforated baskets and is deemed to have entered bypass mode.

The site engineer is responsible for confirming the ultimate bypass capacity of the insert exceeds the design flow to the catch basin for a chosen rain event.

See Table 3.1 – 3.3 in section 3.C. for bypass capacity.

H. Feeder Troughs

The ADS FTC insert does not utilize feeder troughs.

I. Calibration Feature

For ADS drop-in FTC inserts, the side flanges may be adjusted to account for irregularities in the concrete catch basin walls or other obstructions. If there are gaps along the length of the concrete opening greater than 5 mm, loosen the adjustable flange bolt and slide the flange flush with the concrete wall.



J. Previously Trapped Trash

The ADS FTC insert is designed to capture and retain all trash and debris larger than 5mm. The device may re-introduce trash previously captured if the unit is not properly installed or maintained. If laden trash accumulates above the maximum trash capture capacity, the water level rises to reach the bypass allowing floatable, suspended, or buoyant trash and debris to pass.

K. Photographs, if any, of pre-and post-installation examples

Below are sample photos of ADS FTC installed:



L. Material Type

All ADS FTC inserts are constructed entirely of high strength, non-corrosive 304 stainless steel.

- Filter Basket: 14GA perforated 304 stainless-steel uniformly perforated with 5mm (3/16") holes in a staggered pattern. The screen has 50% net open area and retains particles 5mm or greater. The filter basket is secured by 5/16" 316 stainless steel bolts and rivets, then spot welded for additional strength.
- Channel Framing: 0.5" x 1.25" x 0.5" 12GA U-channel stiffeners outline the frame of the filter and are connected by 11GA corner brackets. This fixed construction provides incredible resilience to bending and torsional stresses induced by the weight of the basket.
- Mounting Flanges: FTC baskets rest on two or four 13GA stainless steel flanges bolted to the 12 GA corner brackets.
- Side Flanges: 16GA 304 stainless steel flanges bolted on a 1" adjustable slot to the mounting flanges.
- Bolts and Rivets: 5/16" 316 stainless steel bolts, nuts, and rivets.

M. Design Life

The estimated design life for ADS FTC inserts is a minimum of 25 years when used in storm water applications exposed to moderate levels of salt and other naturally occurring roadway contaminants. All components are made from 304 Stainless Steel to extend the service life. The true design life of the product is dependent upon proper application use and regular maintenance.

4. Installation Guidance

A. Standard Device Installation Procedures and Considerations

All ADS CPS are brought to the field pre-configured for easy assembly based on the specific dimensions provided by the installer.

A typical installation of a drop-in FTC insert follows the steps below:

1. Remove the grate from the inlet.
2. Clean debris from the ledges of the inlet.
3. Place the FTC insert onto the load bearing ledges of the structure.
4. If there are gaps along the length of the concrete opening greater than 5 mm, loosen the adjustable flange bolt and slide the flange flush with the concrete wall.
5. Replace the grate and confirm it is not elevated more than 1/8" (3mm).

A typical installation of a drop-in FTC insert follows the steps below:

1. Remove the grate from the manhole.
2. Lower the FTC Insert into the catch basin through the manhole opening.
3. Mark the wall mount support bracket locations on the basin wall beneath the street/curb opening.
4. Using a hammer drill, install the provided wedge anchor bolts into the concrete wall and secure the support brackets.
5. Lift the unit and engage the support brackets allowing the basket to hang cantilevered off the wall for quick installation and removal.
6. For multiple lengths on longer curb openings, simply use the dual support brackets securing the baskets side by side to cover the entire curb span.
7. Replace the grate onto the manhole.

B. Description of Device Installation Limitations and/or Non-Standard Device Installation Procedures

The ADS FTC Inserts are designed for easy installation such that there are no installation limitations or special instructions needed.

C. Methods for Diagnosing and Correcting Installation Errors

ADS offers FTC inserts in standard sized configurations. However, some catch basin drainage structures require custom designs. Customers are responsible for providing the relevant dimensional information through an ADS dimensional form, a casting reference, a pre-caster detail to ensure proper fabrication of the filter insert.

5. Operation and Maintenance Information

A. Device Inspection Procedures and Inspection Frequency Considerations

ADS FTC inspections should occur every three (3) months and following rain events greater than ½" (13mm). Sites with greater Total Maximal Daily Loads (TMDLs) may need more frequent inspection.

To inspect an FTC insert, remove the grate and confirm visual access to the basket. If the unit is more than half filled with trash, follow the maintenance guidelines outlined in Section 5C. For wall mounted FTC inserts, inspection may require a confined space entry if visual access to the basket is not possible through the curb open throat.

B. Maintenance Frequency

ADS advises that FTC inserts be cleaned out at least four (4) times per year and/or if debris has filled above a 50% level of basket height. Sites with large amounts of foliage, high trash loads, or smaller FTC inserts may need to be cleaned at more frequent intervals. Purchasers must also comply with any minimum maintenance requirements in the applicable Municipal stormwater permit for which the purchaser is regulated.

As with all storm water BMPs, inspection and maintenance must occur on a regular basis, or the filtering mechanism can be overloaded and rendered useless. In such a case, the FTC basket may become filled with trash and debris, lowering the treated flow rate and retention capacity. Any trash and debris entering the inlet may escape directly into the storm sewer system over the top of the FTC basket if bypass mode is reached.

C. Maintenance Procedures

ADS suggests that its FTC inserts be maintained per this set of industry accepted conditions.

Description of Maintenance Actions:

1. After donning the appropriate PPE, remove the grate.
2. Clean the suspended filter by hand, industrial vacuum, or vacuum truck. Alternatively, the filter may be removed from the inlet structure, its content emptied into a receptacle and disposed of properly.
3. Remove any compacted silt and organics from the basket and flush with a medium spray.
4. Inspect the basket for blinding of the perforated sheet and bypass before reinstallation.
5. Replace grate. For wall mounted filters, maintenance may require a confined space entry.

Method of Removal: All trash and debris required to be removed from the FTC insert shall be removed in a manner to be determined by the Contractor. This can be done by hand or with a truck mounted vacuum. If entering the catch basin to clean a wall mounted FTC, ensure that local and federal confined space entry procedures are followed. The Contractor shall not allow any trash or debris to enter the main line because of the cleanout operations.

Debris Disposal: All trash and debris removed under this Contract shall become the property of the Contractor and shall be legally disposed of away from the catch basin sites. The Contractor is responsible for proper disposal of the trash and debris, including obtaining approvals from all jurisdictional agencies, as applicable. The contractor shall be responsible for contacting and coordinating with local Animal Care and Control for pickup and disposal of dead animals.

D. Essential equipment and materials for proper maintenance activities.

Suggested method for maintenance is utilization of a vacuum truck combined with a power washer / high pressure hose. If a vacuum truck is not available, the catch basin may be cleaned manually with a shovel and trash receptacle. Proper PPE includes gloves, safety boots, eye protection, and any additional PPE or site safety items required for traffic control or confined space entry.

E. Description of the effects of deferred maintenance on device structural integrity, performance, odors, etc.

In the event of deferred maintenance, the filter baskets may become filled with trash and debris, lowering the flow rate capacity until reaching the ultimate bypass which would still allow full water flow

but without filtration. Deferred maintenance may also allow the basket to fill with trash and debris above the maximum trash level, trash which could be reintroduced into the water system during a major storm event. The build-up of certain trash and debris could allow for odors to form and drift out of the catch basin.

F. Repair procedures for the device’s structural and screening components.

If the perforated steel is damaged or dented, it will still function provided no opening exceeds 5 mm. In the event the steel framing system is damaged to the point where the support flanges do not sit flush on the catch basin frame, the contractor may attempt to straighten or flatten the damaged area. If the damage is beyond repair, it is recommended to replace the entire unit.

6. Vector Control Accessibility

A. Description of Vector Control Accessibility

Personnel can administer vector control to the bottom of the catch basin through the 4” hinged bypass lid on the FTC “VC” framing. Wall mount filters in curb inlets allow for visual inspection above the suspended filter through the curb opening. Curb inlets are typically inspected and serviced through the manhole entry.

B. System Drawings of Vector Control Accessibility

ADS FULL CAPTURE INSERTS - VECTOR CONTROL (VC) VERSION

Support flanges have a 4.5” drop for standard flat bottom grates. If heavy duty traffic grate is specified then this flange would be dropped down another 1”-3” to allow for hinged lid clearance.

4” wide hinged flange for vector control access. This will run the entire length of any 12”-36” wide catch basin. The flange should be located over the outlet pipe when filter is installed.

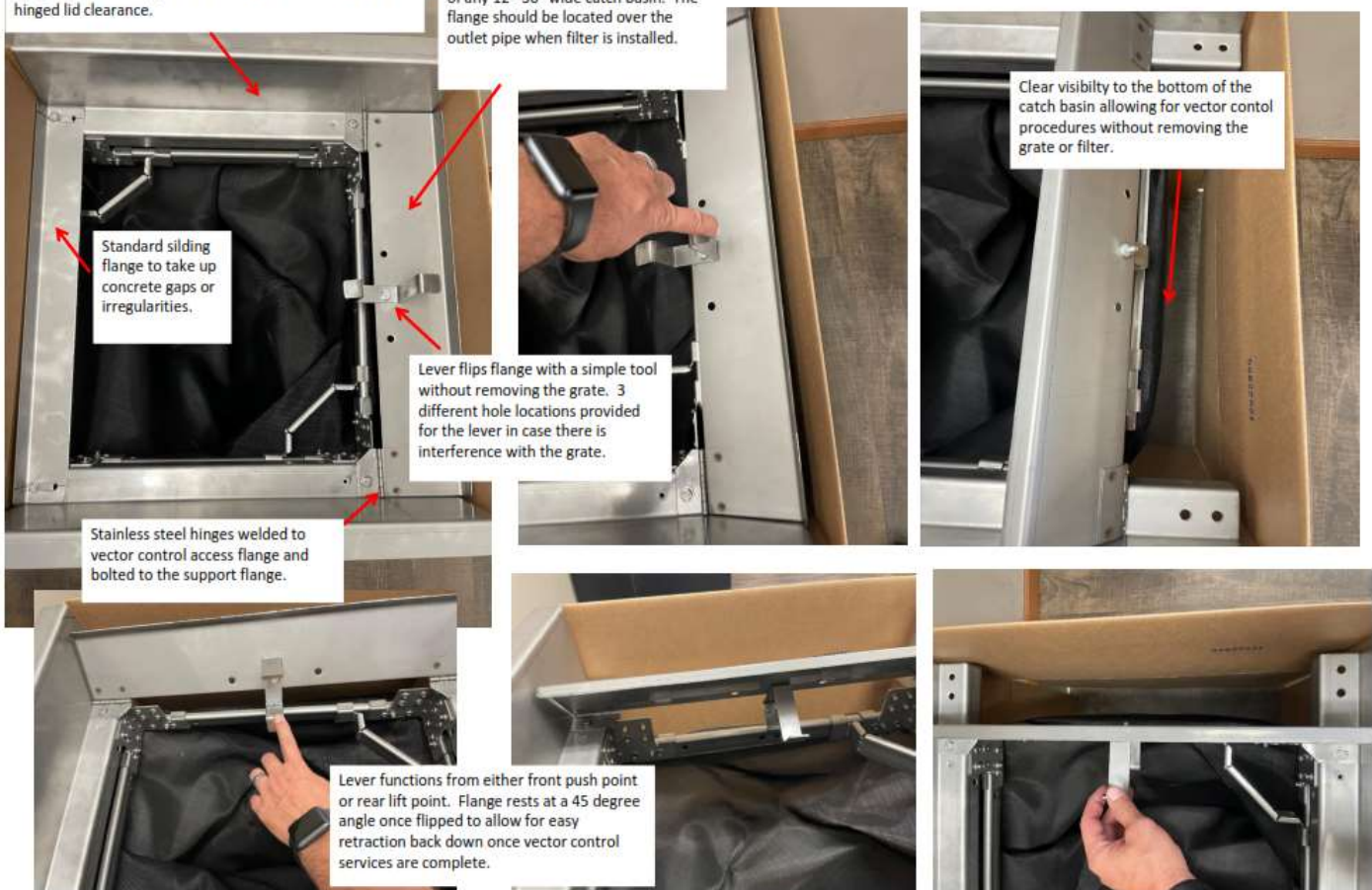

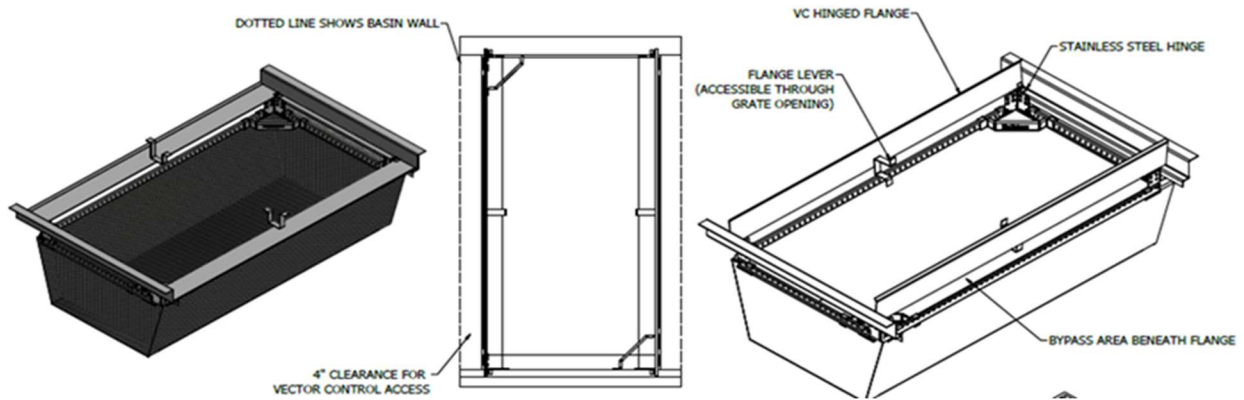

C. Date of Application Submittal to Mosquito Vector Control Association

ADS FTC Insert vector control design details were submitted to MVCAC and the Trash Treatment Control Committee on November 6, 2024.

D. Mosquito Vector Control Association of California Letter of Verification

Verification letter added to Appendix B on November 27, 2024.

7. Reliability Information:

A. Estimated design life of device components before major overhaul.

As mentioned in section 3L, the 304 Stainless Steel components in the ADS FTC inserts have a minimum of 25-year design life when used in storm water applications exposed to moderate levels of salt and other naturally occurring roadway contaminants. The loading for each sized insert is considered and the support materials have been tested with considerable safety factor based on 125 lbs. per cubic ft. storage capacity.

B. Warranty information.

ADS warrants the Full Trash Capture (FTC) Insert to be free of defects in material and workmanship in accordance with proper installation, normal use, and service for a period of five (5) years from the date of shipment.

This warranty is limited to repair or replacement of any part or components that, upon examination by ADS, have been defective in material or workmanship. Damaged FTC inserts due to negligence or lack of maintenance are not covered.

C. Customer Support Information

For any technical information or support, customers may reach out to:
 Advanced Drainage Systems, Inc.
 24137 111th Street
 Naperville, IL 60564
 Email: flexstorm@adspipe.com
 Website: www.adspipe.com/support/contact-us

8. Field/Lab Testing Information and Analysis

- A. For devices with 5mm screening, any available field/lab testing information that demonstrates the device functionality and performance.**

All ADS FTC inserts are made of screen with 3/16" (5mm) openings. Field/lab testing is not required because all particles and debris larger than 5mm would be trapped by the basket.

APPENDIX A

ADS FLEXSTORM FULL TRASH CAPTURE INLET FILTERS WITH VECTOR CONTROL ACCESS

Certified by California Water Board & CASQA

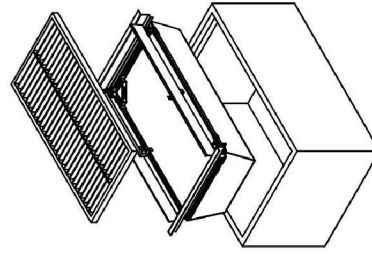
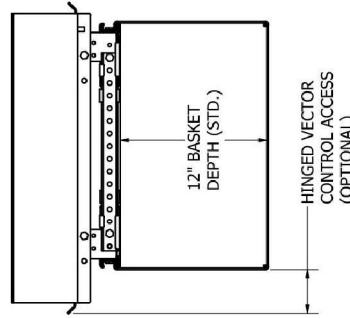
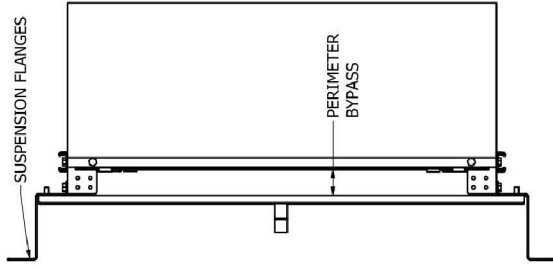
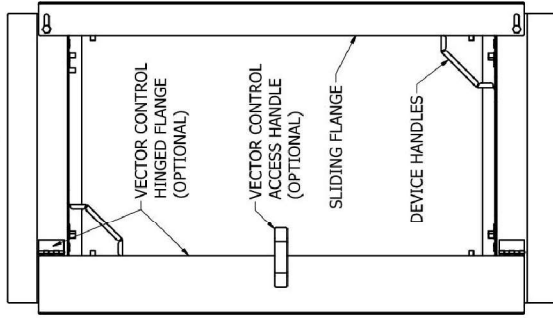
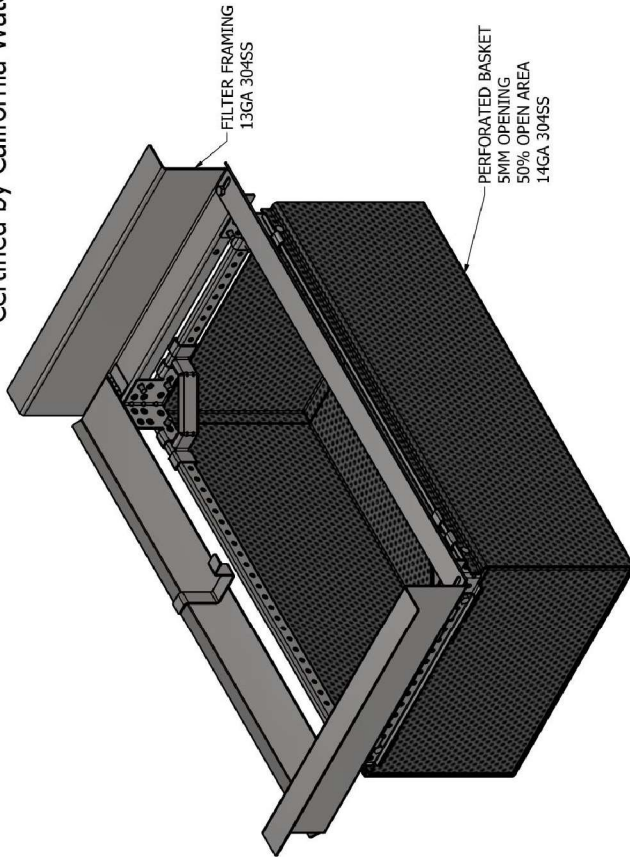

VECTOR CONTROL FTC P/N	INLET BASIN SIZE	STORAGE CAPACITY (CF)	TREATED FLOW RATE AT EMPTY (CFS)	TREATED FLOW RATE AT 50% CAPACITY (CFS)	BYPASS FLOW RATE (CFS)*
62HD18FTC-VC	18" X 18"	1.2	9.8	2.7	3
62HD24FTC-VC	24" X 24"	2.6	13.5	3.4	4.5
62HD3618FTC-VC	36" X 18"	2.8	15.4	3.9	5.6
62HD3624FTC-VC	36" X 24"	4.2	18.9	4.5	6.1
62HD36FTC-VC	36" X 36"	5.6	30.8	7.8	11.2

*Bypass values based on driving head for 4" standing water over 2" thick grate. Values are not inclusive of treated flows through perforated basket.

NOTES:

1. DEVICE FRAMING, BASKET, AND HARDWARE CONSTRUCTED OF 304 STAINLESS STEEL.
2. MINIMUM STRUCTURE DEPTH REQUIREMENT OF 24".
3. VECTOR CONTROL COMPLIANT FTC DEVICES ONLY AVAILABLE IN SIZING LISTED.

INSTALLATION INSTRUCTIONS:

1. REMOVE GRATE FROM DRAINAGE STRUCTURE.
2. CLEAN GRATE LEDGE/LIP OF DEBRIS.
3. SET INLET FILTER ON LOAD BEARING LEDGES OF STRUCTURE.
4. REPLACE GRATE ON TOP OF DEVICE SUSPENSION FLANGES.

ALL PRODUCTS MANUFACTURED BY ADVANCED DRAINAGE SYSTEMS
WWW.ADSPIPE.COM
PH. 1-800-821-6710



SIZE	DATE	DWG NO	REV
C	09/17/2024	ADS FLEXSTORM FTC-VC	A
SCALE: N/A			SHEET 1 OF 1

ADS FLEXSTORM PURE FULL TRASH CAPTURE INLET FILTERS

Certified by California Water Board & CASQA

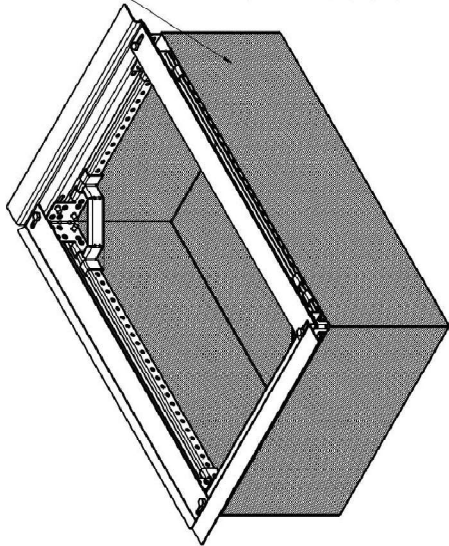

14 GA. 304 SS PERFORATED BASKETS
(5MM (0.196") OPENINGS / 50% OPEN AREA)

SQUARE/RECTANGULAR INLET FILTER				
Clear Opening Size	Style P/N	Min. Bypass Flow Rate (CFS)	Min. Empty Treated Flow (CFS)	Min. Storage Capacity (Cu.Ft.)
Small: Up to 64" Perimeter	62SHDFTC	1.7	6.5	0.8
Medium: 65" - 96" Perimeter	62MHDFTC	2.5	9.4	1.5
Large: 97" - 120" Perimeter	62LHDFTC	3.7	16	3.3

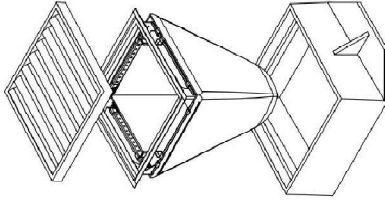

OVERFLOW BYPASS AREA EXCEEDS
FLOW RATE OF DRAINAGE LOCATION

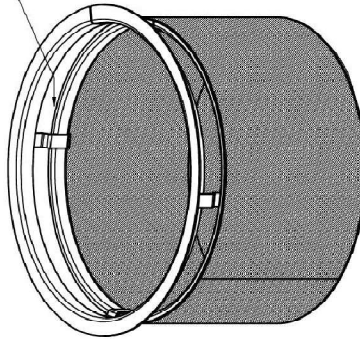

ROUND INLET FILTER				
Clear Opening Size	Style P/N	Min. Bypass Flow Rate (CFS)	Min. Empty Treated Flow (CFS)	Min. Storage Capacity (Cu.Ft.)
Small: 10" - 16" Dia.	62SHDRFTC	1.6	4.9	0.5
Medium: 17" - 24" Dia.	62MHRFTC	2.7	9.4	1.6
Large: 25" - 36" Dia.	62LHRFTC	3.9	16.2	2.8

LIFT HANDLES

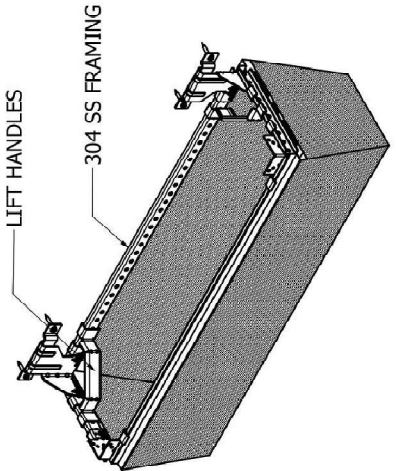

CURB OPEN THROAT INLET FILTER				
Curb Opening Size	Style P/N	Min. Empty Treated Flow (CFS)	Min. Storage Capacity (Cu.Ft.)	
1' - 4' Width (1-Piece Set)	62HDWM1FTC	7.1	0.9	
4' - 8' Width (2-Piece Set)	62HDWM2FTC	20.3	3.6	
8' - 12' Width (3-Piece Set)	62HDWM3FTC	37.8	7.2	
12' - 16' Width (4-Piece Set)	62HDWM4FTC	55.4	10.3	

INSTALLATION INSTRUCTIONS:

1. REMOVE GRATE
2. CLEAN GRATE LEDGE
3. SET INLET FILTER ON LOAD BEARING LEDGE OF STRUCTURE
4. REPLACE GRATE

NOTES:

1. ALL FRAMING IS CONSTRUCTED OF 304 STAINLESS STEEL.
2. TOTAL BYPASS CAPACITY WILL VARY WITH EACH SIZE DRAINAGE STRUCTURE. ADS DESIGNS FRAMING BYPASS TO MEET OR EXCEED THE DESIGN FLOW OF THE PARTICULAR DRAINAGE STRUCTURE.
3. UPON ORDERING, CONFIRMATION OF THE INLET SPECIFICATION, PRECAST/FOUNDRY CASTING MAKE AND MODEL, OR DETAILED DIMENSIONAL FORMS MUST BE PROVIDED TO CONFIGURE AND ASSEMBLE AN INLET FILTER.
4. ALL FILTERS MEET ASTM D8057 SPECIFICATIONS.
5. FOR WRITTEN SPECIFICATIONS AND MAINTENANCE GUIDELINES VISIT WWW.ADSPICE.COM.

ALL PRODUCTS MANUFACTURED
BY ADVANCED DRAINAGE SYSTEMS
WWW.ADSPICE.COM
PH. 1-800-821-6710



DATE	DWG NO	REV
10/23/2024	ADS FLEXSTORM PURE (FTC)	A
SCALE	N/A	SHEET 1 OF 1

ADS FLEXSTORM FULL TRASH CAPTURE INLET FILTERS FOR NYLOPLAST BASINS

Certified by California Water Board & CASQA

FILTER SPECIFICATIONS BY NOMINAL SIZE					
NOMINAL FILTER SIZE FOR NYLOPLAST BASINS	FILTER PART NUMBER	SOLIDS STORAGE (CuFt)	TREATED FLOW AT EMPTY	TREATED FLOW RATE 50% FULL (CFS)*	BYPASS FLOW RATE (CFS)
12" DIA.	6212NYFTC	0.5	4.8	1.4	1.7
15" DIA.	6215NYFTC	0.9	6.5	1.8	2.1
18" DIA.	6218NYFTC	1.4	8.4	2.2	2.6
24" DIA.	6224NYFTC	2.5	12.3	3	3.5
30" DIA.	6230NYFTC	4.2	17.5	3.9	4.5

14 GA. 304 SS PERFORATED BASKETS (5MM (0.196") OPENINGS / 50% OPEN AREA)

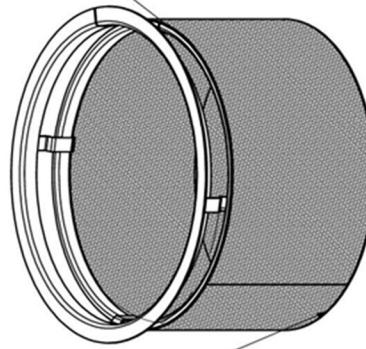

OVERFLOW BYPASS AREA EXCEEDS FLOW RATE OF DRAINAGE STRUCTURE

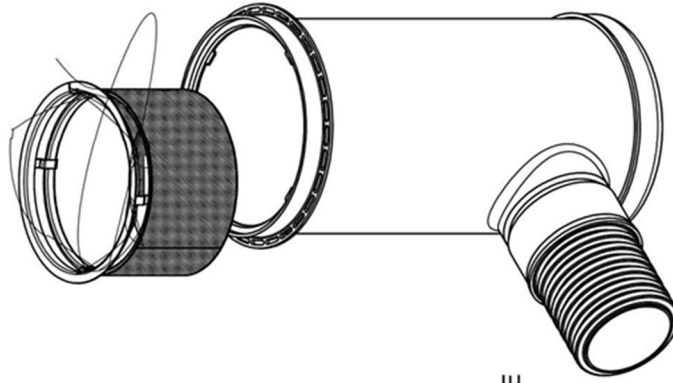

NOTES:

- ALL FRAMING IS CONSTRUCTED OF 304 STAINLESS STEEL.
- TOTAL BYPASS CAPACITY WILL VARY WITH EACH SIZE DRAINAGE STRUCTURE. ADS DESIGNS FRAMING BYPASS TO MEET OR EXCEED THE DESIGN FLOW OF THE PARTICULAR DRAINAGE STRUCTURE.
- CONFIRMATION OF THE NYLOPLAST DRAIN BASIN DETAILS AND GRATE STYLE MUST BE PROVIDED TO ENSURE PROPER FILTER SELECTION AND USE OF TRANSITION PLATES OR HANGER KITS (IF REQUIRED).
- ALL FILTERS MEET ASTM D8057 SPECIFICATIONS.
- FOR WRITTEN SPECIFICATIONS AND MAINTENANCE GUIDELINES VISIT WWW.ADSPPIPE.COM.

INSTALLATION INSTRUCTIONS:

- REMOVE GRATE
- CLEAN GRATE LEDGE
- SET INLET FILTER ON LOAD BEARING LEDGE OF STRUCTURE
- REPLACE GRATE

TITLE
 ALL PRODUCTS MANUFACTURED BY ADVANCED DRAINAGE SYSTEMS
 WWW.ADSPPIPE.COM
 PH. 1-800-821-6710
Our reason is water.™

SIZE C DWG NO ADS FlexStorm FTC (Nylo)
SCALE 0:10

REV
 SHEET 1 OF 1

APPENDIX B

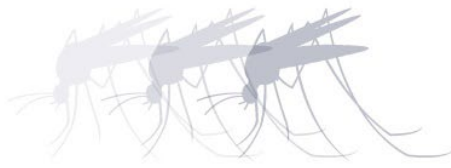

MVCAC
Mosquito and Vector Control Association of California

One Capitol Mall, Suite 320 • Sacramento, CA 95814 • p: (916) 440-0826 • f: (916) 444-7462 • e: mvcac@mvcac.org

ADS - Flexstorm
24137 111th Street
Naperville, IL 60564

November 26, 2024

Dear Amanda Toth,

Thank you for the submission of the ADS-Flexstorm revised Full Trash Capture (FTC) insert for review by the Mosquito and Vector Control Association of California pursuant to the SWRCB Trash Treatment Control Device Application Requirements. The Association has reviewed the conceptual drawings for the ADS-Flexstorm Revised FTC insert and verifies that provisions have been included in the design that allow for full visual access to all areas for presence of standing water, and when necessary, allows for treatments of mosquitoes.

The following is a recommendation for installations and not a contingency to certification. The Mosquito and Vector Control Association recommends the filter insert be installed with the inspection hatch as close to the discharge pipe as possible. This will provide the best possible visual assessment of the basin for standing water.

While this verification letter confirms that inspection and treatment for the purpose of minimizing mosquito production should be possible with the ADS-Flexstorm revised FTC insert as presented, it does not affect the local mosquito control agency's rights and remedies under the State Mosquito Abatement and Vector Control District Law. For example, if the installed device or the associated stormwater system infrastructure becomes a mosquito breeding source, it may be determined by a local mosquito control agency to be a public nuisance in accordance with California Health and Safety Code sections 2060-2067.

"Public nuisance" means any of the following:

1. Any property, excluding water, that has been artificially altered from its natural condition so that it now supports the development, attraction, or harborage of vectors. The presence of vectors in their developmental stages on a property is prima facie evidence that the property is a public nuisance.
2. Any water that is a breeding place for vectors. The presence of vectors in their developmental stages in the water is prima facie evidence that the water is a public nuisance.
3. Any activity that supports the development, attraction, or harborage of vectors, or that facilitates the introduction or spread of vectors. (Heal. & Saf. Code § 2002 (j).)

Declaration of a facility or property as a public nuisance may result in penalties as provided under the Health and Safety Code. Municipalities and the vendors they work with are encouraged to discuss the design, installation, and maintenance of stormwater trash capture devices with their local mosquito control agency to reduce the potential for disease transmission and public nuisance associated with mosquito production.

Sincerely,

Megan MacNee
MVCAC Executive Director